

Operating Instructions

Radar sensor for continuous level measurement of liquids

VEGAPULS 61

4 ... 20 mA/HART - two-wire



Document ID: 36499



VEGA

Contents

1	About this document	
1.1	Function	4
1.2	Target group	4
1.3	Symbols used.....	4
2	For your safety	
2.1	Authorised personnel	5
2.2	Appropriate use.....	5
2.3	Warning about incorrect use.....	5
2.4	General safety instructions	5
2.5	CE conformity.....	6
2.6	NAMUR recommendations	6
2.7	Radio license for Europe	6
2.8	Radio license for USA/Canada.....	6
2.9	Environmental instructions	7
3	Product description	
3.1	Configuration.....	8
3.2	Principle of operation.....	9
3.3	Packaging, transport and storage.....	10
3.4	Accessories and replacement parts	10
4	Mounting	
4.1	General instructions	13
4.2	Collar or adapter flange	14
4.3	Mounting preparations, mounting strap	14
4.4	Mounting instructions	15
4.5	Measurement setup - Pipes	21
4.6	Measurement setup - Flow	26
5	Connecting to power supply	
5.1	Preparing the connection	28
5.2	Connecting.....	29
5.3	Wiring plan, single chamber housing.....	30
5.4	Wiring plan, double chamber housing	31
5.5	Wiring plan, double chamber housing Ex d ia	33
5.6	Double chamber housing with DISADAPT	34
5.7	Wiring plan - version IP 66/IP 68, 1 bar.....	35
5.8	Switch-on phase.....	35
6	Set up with the display and adjustment module	
6.1	Insert display and adjustment module	36
6.2	Adjustment system	37
6.3	Measured value indication - Selection national language.....	38
6.4	Parameter adjustment	39
6.5	Saving the parameter adjustment data.....	58
7	Setup with PACTware	
7.1	Connect the PC.....	59
7.2	Parameter adjustment	60
7.3	Saving the parameter adjustment data.....	61

8	Set up with other systems	
8.1	DD adjustment programs	62
8.2	Field Communicator 375, 475	62
9	Diagnosis, asset management and service	
9.1	Maintenance	63
9.2	Measured value and event memory	63
9.3	Asset Management function.....	64
9.4	Rectify faults.....	67
9.5	Exchanging the electronics module.....	71
9.6	Software update	72
9.7	How to proceed if a repair is necessary.....	72
10	Dismount	
10.1	Dismounting steps.....	73
10.2	Disposal	73
11	Supplement	
11.1	Technical data	74
11.2	Dimensions	81



Safety instructions for Ex areas

Take note of the Ex specific safety instructions for Ex applications. These instructions are attached as documents to each instrument with Ex approval and are part of the operating instructions manual.

Editing status: 2015-06-17

1 About this document

1.1 Function

This operating instructions manual provides all the information you need for mounting, connection and setup as well as important instructions for maintenance and fault rectification. Please read this information before putting the instrument into operation and keep this manual accessible in the immediate vicinity of the device.

1.2 Target group

This operating instructions manual is directed to trained specialist personnel. The contents of this manual should be made available to these personnel and put into practice by them.

1.3 Symbols used



Information, tip, note

This symbol indicates helpful additional information.



Caution: If this warning is ignored, faults or malfunctions can result.



Warning: If this warning is ignored, injury to persons and/or serious damage to the instrument can result.



Danger: If this warning is ignored, serious injury to persons and/or destruction of the instrument can result.



Ex applications

This symbol indicates special instructions for Ex applications.



List

The dot set in front indicates a list with no implied sequence.



Action

This arrow indicates a single action.



Sequence of actions

Numbers set in front indicate successive steps in a procedure.



Battery disposal

This symbol indicates special information about the disposal of batteries and accumulators.

2 For your safety

2.1 Authorised personnel

All operations described in this operating instructions manual must be carried out only by trained specialist personnel authorised by the plant operator.

During work on and with the device the required personal protective equipment must always be worn.

2.2 Appropriate use

VEGAPULS 61 is a sensor for continuous level measurement.

You can find detailed information about the area of application in chapter "*Product description*".

Operational reliability is ensured only if the instrument is properly used according to the specifications in the operating instructions manual as well as possible supplementary instructions.

2.3 Warning about incorrect use

Inappropriate or incorrect use of the instrument can give rise to application-specific hazards, e.g. vessel overflow or damage to system components through incorrect mounting or adjustment. Also the protective characteristics of the instrument can be influenced.

2.4 General safety instructions

This is a state-of-the-art instrument complying with all prevailing regulations and guidelines. The instrument must only be operated in a technically flawless and reliable condition. The operator is responsible for the trouble-free operation of the instrument.

During the entire duration of use, the user is obliged to determine the compliance of the necessary occupational safety measures with the current valid rules and regulations and also take note of new regulations.

The safety instructions in this operating instructions manual, the national installation standards as well as the valid safety regulations and accident prevention rules must be observed by the user.

For safety and warranty reasons, any invasive work on the device beyond that described in the operating instructions manual may be carried out only by personnel authorised by the manufacturer. Arbitrary conversions or modifications are explicitly forbidden.

The safety approval markings and safety tips on the device must also be observed.

Depending on the instrument version, the emitting frequencies are in the C, K or W band range. The low emitting frequencies are far below the internationally approved limit values. When used correctly, the device poses no danger to health.

2.5 CE conformity

The device fulfills the legal requirements of the applicable EC guidelines. By affixing the CE marking, we confirm successful testing of the product.

You can find the CE Certificate of Conformity in the download section of our homepage.

Electromagnetic compatibility

Instruments in four-wire or Ex-d-ia version are designed for use in an industrial environment. Nevertheless, electromagnetic interference from electrical conductors and radiated emissions must be taken into account, as is usual with class A instruments according to EN 61326-1. If the instrument is used in a different environment, the electromagnetic compatibility to other instruments must be ensured by suitable measures.

2.6 NAMUR recommendations

NAMUR is the automation technology user association in the process industry in Germany. The published NAMUR recommendations are accepted as the standard in field instrumentation.

The device fulfills the requirements of the following NAMUR recommendations:

- NE 21 – Electromagnetic compatibility of equipment
- NE 43 – Signal level for malfunction information from measuring transducers
- NE 53 – Compatibility of field devices and display/adjustment components
- NE 107 – Self-monitoring and diagnosis of field devices

For further information see www.namur.de.

2.7 Radio license for Europe

The instrument is approved according to EN 302372-1/2 (2006-04) for use in closed vessels.

2.8 Radio license for USA/Canada

The instrument is in conformity with part 15 of the FCC regulations. Take note of the following two regulations:

- This device may not cause interference, and
- This device must accept any interference, including interference that may cause undesired operation of the device

Modifications not expressly approved by the manufacturer will lead to expiry of the operating licence according to FCC/IC.

The instrument is in conformity with RSS-210 of the IC regulations.

The instrument may only be used in closed vessels made of metal, concrete, or fibre-reinforced plastic.

2.9 Environmental instructions

Protection of the environment is one of our most important duties. That is why we have introduced an environment management system with the goal of continuously improving company environmental protection. The environment management system is certified according to DIN EN ISO 14001.

Please help us fulfill this obligation by observing the environmental instructions in this manual:

- Chapter "*Packaging, transport and storage*"
- Chapter "*Disposal*"

3 Product description

3.1 Configuration

Type label

The type label contains the most important data for identification and use of the instrument:

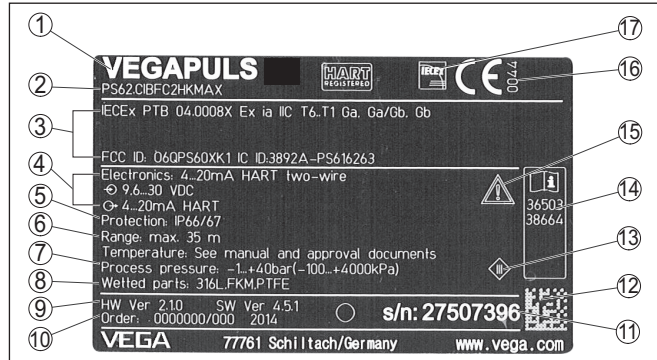

Fig. 1: Layout of the type label (example)

- 1 Instrument type
- 2 Product code
- 3 Approvals
- 4 Power supply and signal output, electronics
- 5 Protection rating
- 6 Measuring range
- 7 Process and ambient temperature, process pressure
- 8 Material, wetted parts
- 9 Hardware and software version
- 10 Order number
- 11 Serial number of the instrument
- 12 Data-Matrix-Code for smartphone app
- 13 Symbol of the device protection class
- 14 ID numbers, instrument documentation
- 15 Reminder to observe the instrument documentation
- 16 Notified authority for CE marking
- 17 Approval directive

Serial number - Instrument search

The type label contains the serial number of the instrument. With it you can find the following instrument data on our homepage:

- Product code (HTML)
- Delivery date (HTML)
- Order-specific instrument features (HTML)
- Operating instructions and quick setup guide at the time of shipment (PDF)
- Order-specific sensor data for an electronics exchange (XML)
- Test certificate (PDF) - optional

Go to www.vega.com, "VEGA Tools" and "Instrument search". Enter the serial number.

Alternatively, you can access the data via your smartphone:

- Download the smartphone app "VEGA Tools" from the "Apple App Store" or the "Google Play Store"
- Scan the Data Matrix code on the type label of the instrument or
- Enter the serial number manually in the app

Scope of this operating instructions manual

This operating instructions manual applies to the following instrument versions:

- Hardware version from 2.1.0
- Software version from 4.5.1

Versions

The instrument is available in two different electronics versions. Each version can be identified via the product code on the type label as well as on the electronics.

- Standard electronics type PS60HK.-
- Electronics with increased sensitivity type PS60HS.-

Scope of delivery

The scope of delivery encompasses:

- Radar sensor
- Optional mounting accessory
- Documentation
 - Quick setup guide VEGAPULS 61
 - Instructions for optional instrument features
 - Ex-specific "Safety instructions" (with Ex versions)
 - if necessary, further certificates
- DVD "Software", included therein
 - PACTware/DTM Collection
 - Driver software



Information:

In the operating instructions manual, the optional instrument features are described. The respective scope of delivery results from the order specification.

Application area

3.2 Principle of operation

The VEGAPULS 61 is a radar sensor for continuous level measurement of liquids under simple process conditions.

Dependent on the application range, different versions are used:

- Level measurement of aggressive liquids in small vessels: **encapsulated antenna system**
- Flow measurement in open flumes or gauge measurement of bodies of water: **Plastic horn antenna**
- Products with an ϵ_r value ≥ 1.8 : **Standard electronics**
- Products with an ϵ_r value $\geq 1.5, < 1.8$; applications with very poor reflective properties: **Electronics with increased sensitivity**

The actual values that can be reached depend on the measurement conditions, the antenna system or the standpipe or bypass.

Functional principle The antenna of the radar sensor emits short radar pulses with a duration of approx. 1 ns. These pulses are reflected by the product and received by the antenna as echoes. The transit time of the radar pulses from emission to reception is proportional to the distance and hence to the level. The determined level is converted into an appropriate output signal and outputted as measured value.

3.3 Packaging, transport and storage

Packaging Your instrument was protected by packaging during transport. Its capacity to handle normal loads during transport is assured by a test based on ISO 4180.

The packaging of standard instruments consists of environment-friendly, recyclable cardboard. For special versions, PE foam or PE foil is also used. Dispose of the packaging material via specialised recycling companies.

Transport Transport must be carried out in due consideration of the notes on the transport packaging. Nonobservance of these instructions can cause damage to the device.

Transport inspection The delivery must be checked for completeness and possible transit damage immediately at receipt. Ascertained transit damage or concealed defects must be appropriately dealt with.

Storage Up to the time of installation, the packages must be left closed and stored according to the orientation and storage markings on the outside.

Unless otherwise indicated, the packages must be stored only under the following conditions:

- Not in the open
- Dry and dust free
- Not exposed to corrosive media
- Protected against solar radiation
- Avoiding mechanical shock and vibration

Storage and transport temperature

- Storage and transport temperature see chapter "*Supplement - Technical data - Ambient conditions*"
- Relative humidity 20 ... 85 %

3.4 Accessories and replacement parts

PLICSCOM The display and adjustment module PLICSCOM is used for measured value indication, adjustment and diagnosis. It can be inserted into the sensor or the external display and adjustment unit and removed at any time.

You can find further information in the operating instructions "*Display and adjustment module PLICSCOM*" (Document-ID 27835).

VEGACONNECT The interface adapter VEGACONNECT enables the connection of communication-capable instruments to the USB interface of a PC. For

parameter adjustment of these instruments, the adjustment software PACTware with VEGA-DTM is required.

You can find further information in the operating instructions "*Interface adapter VEGACONNECT*" (Document-ID 32628).

VEGADIS 81

The VEGADIS 81 is an external display and adjustment unit for VEGA plics® sensors.

For sensors with double chamber housing the interface adapter "*DISADAPT*" is also required for VEGADIS 81.

You can find further information in the operating instructions "*VEGADIS 81*" (Document-ID 43814).

DISADAPT

The adapter "*DISADAPT*" is an accessory part for sensors with double chamber housings. It enables the connection of VEGADIS 81 to the sensor housing via an M12 x 1 plug.

You can find further information in the supplementary instructions "*Adapter DISADAPT*" (Document-ID 45250).

VEGADIS 82

VEGADIS 82 is suitable for measured value indication and adjustment of sensors with HART protocol. It is looped into the 4 ... 20 mA/HART signal cable.

You can find further information in the operating instructions "*VEGADIS 82*" (Document-ID 45300).

PLICSMOBILE T61

PLICSMOBILE T61 is an external GSM/GPRS radio unit for transmission of measured values and for remote parameter adjustment of plics® sensors. Adjustment is carried out via PACTware/DTM and the integrated USB connection.

You can find further information in the supplementary instructions "*PLICSMOBILE T61*" (Document-ID 37700).

PLICSMOBILE

PLICSMOBILE is an internal GSM/GPRS radio unit for transmission of measured values and for remote parameter adjustment of plics® sensors. Adjustment is carried out via PACTware/DTM and the integrated USB connection.

You can find further information in the supplementary instructions "*PLICSMOBILE GSM/GPRS radio module*" (Document-ID 36849).

Protective cap

The protective cover protects the sensor housing against soiling and intense heat from solar radiation.

You will find additional information in the supplementary instructions manual "*Protective cover*" (Document-ID 34296).

Electronics module

Electronics module "*VEGAPULS series 60*" is a replacement part for radar sensors of VEGAPULS series 60. A different version is available for each type of signal output.

You can find further information in the operating instructions "*Electronics module VEGAPULS series 60*" (Document-ID 36801).

Supplementary electronics for double chamber housing

The supplementary electronics is a replacement part for sensors with double chamber housing and 4 ... 20 mA/HART - two-wire.

You can find further information in the operating instructions "*Supplementary electronics for 4 ... 20 mA/HART - two-wire*" (Document-ID 42764).

4 Mounting

4.1 General instructions

Screwing in

On instruments with process fitting thread, the hexagon must be tightened with a suitable wrench. For the proper wrench size see chapter "Dimensions".



Warning:

The housing must not be used to screw the instrument in! Applying tightening force can damage internal parts of the housing.

Protection against moisture

Protect your instrument against moisture ingress through the following measures:

- Use the recommended cable (see chapter "Connecting to power supply")
- Tighten the cable gland
- When mounting horizontally, turn the housing so that the cable gland points downward
- Loop the connection cable downward in front of the cable gland

This applies particularly to:

- Outdoor mounting
- Installations in areas where high humidity is expected (e.g. through cleaning processes)
- Installations on cooled or heated vessels

Suitability for the process conditions

Make sure that all parts of the instrument exposed to the process are suitable for the existing process conditions.

These are mainly:

- Active measuring component
- Process fitting
- Process seal

Process conditions are particularly:

- Process pressure
- Process temperature
- Chemical properties of the medium
- Abrasion and mechanical influences

You can find detailed information on the process conditions in chapter "Technical data" as well as on the type label.

Cable entries - NPT thread

In the case of instrument housings with self-sealing NPT threads, it is not possible to have the cable entries screwed in at the factory. The free openings for the cable glands are therefore covered with red dust protection caps as transport protection.

Prior to setup you have to replace these protective caps with approved cable glands or close the openings with suitable blind plugs.

4.2 Collar or adapter flange

For mounting the instrument on a socket, a combi compression flange for DN 80 (ASME 3" or JIS 80) is also available for retro fitting. Optionally, the instrument can be also equipped with an adapter flange from DN 100 (ASME 4" or JIS 100).

With the housing versions plastic, aluminium single chamber and stainless steel, the collar flange can be placed directly over the housing. With the aluminium double chamber housing, retroactive mounting in this way is not possible - the mounting type must be specified with the order.

You can find drawings of these mounting options in chapter "Dimensions".

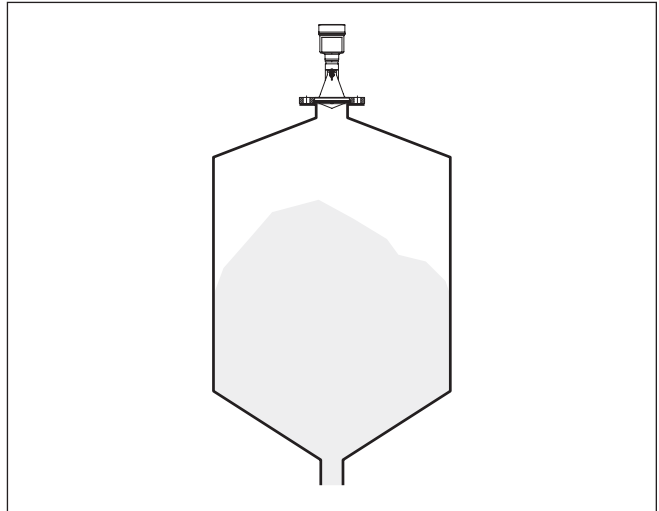

Fig. 2: Flange mounting of the radar sensor

4.3 Mounting preparations, mounting strap

The mounting strap enables simple mounting on the vessel wall or silo top. It is suitable for wall, ceiling or boom mounting. Especially in open vessels this is a very easy and effective way to align the sensor to the bulk solid surface.

The strap is supplied unassembled and must be screwed to the sensor before setup with three hexagon socket screws M5 x 10 and spring washers. Max. torque, see chapter "Technical data". Required tools: Allen wrench size 4.

There are two ways to screw the strap onto the sensor. Depending on the selected version, the sensors can be swivelled in the strap as follows:

- Single chamber housing
 - Angle of inclination 180°, infinitely variable
 - Angle of inclination in three steps 0°, 90° and 180°

- Double chamber housing
 - Angle of inclination 90°, infinitely variable
 - Angle of inclination in two steps 0° and 90°

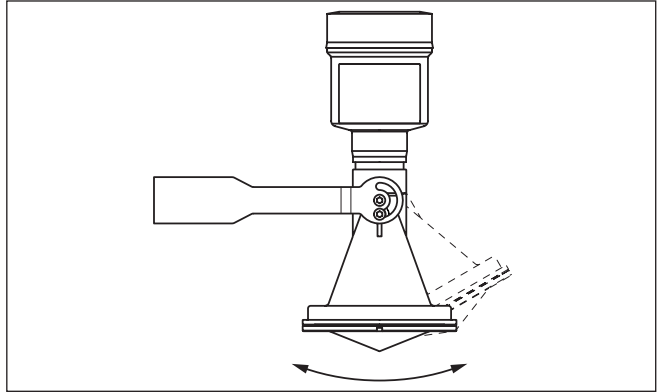

Fig. 3: Adjustment of the angle of inclination

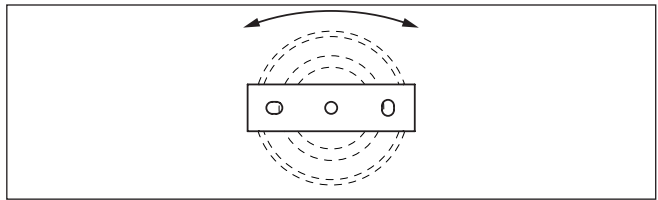

Fig. 4: Turning by fastening in the centre

Tight installation of the plastic horn antenna

For tight installation of the version with plastic horn antenna with compression or adapter flange, the following conditions must be fulfilled:

1. Use suitable flat seal, e.g. of EPDM with Shore hardness 25 or 50
2. Make sure the number of flange screws corresponds to the number of flange holes
3. Tighten all screws with the torque stated in the technical data

Polarisation

The emitted radar impulses of the radar sensor are electromagnetic waves. The polarisation is the direction of the electrical wave component. By turning the instrument in the connection flange or mounting boss, the polarisation can be used to reduce the effects of false echoes.

The position of the polarisation is marked on the process fitting of the instrument.

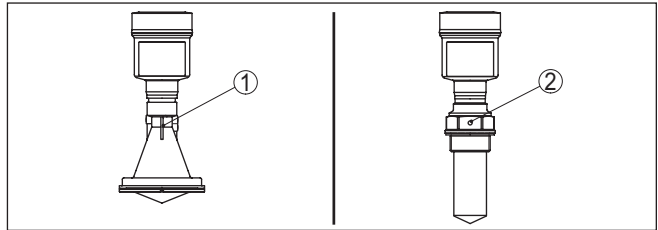

Fig. 5: Position of the polarisation

- 1 Marking with version with plastic horn antenna
- 2 Marking with version with encapsulated antenna system

Installation position

When mounting the sensor, keep a distance of at least 200 mm (7.874 in) to the vessel wall. If the sensor is installed in the center of dished or round vessel tops, multiple echoes can arise. These can, however, be suppressed by an appropriate adjustment (see chapter "Setup").

If you cannot maintain this distance, you should carry out a false signal storage during setup. This applies particularly if buildup on the vessel wall is expected. In such cases, we recommend repeating the false signal storage at a later date with existing buildup.

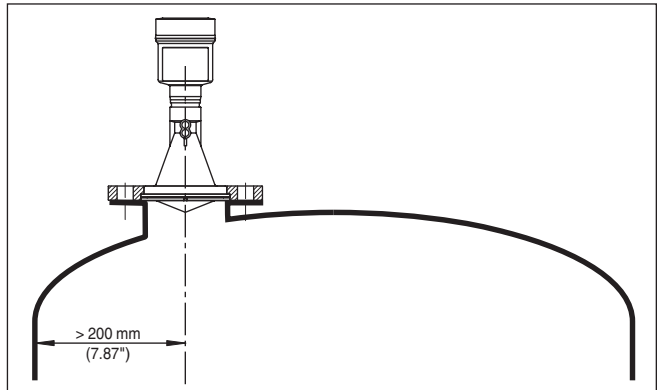

Fig. 6: Mounting of the radar sensor on round vessel tops

In vessels with conical bottom it can be advantageous to mount the sensor in the center of the vessel, as measurement is then possible down to the lowest point of the vessel bottom.

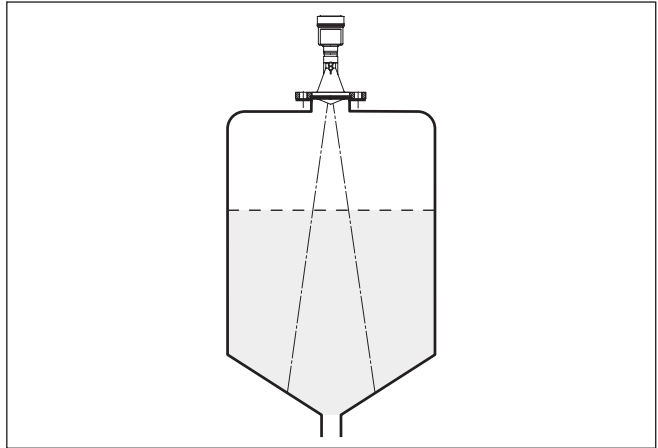

Fig. 7: Mounting of the radar sensor on vessels with conical bottom

Inflowing medium

Do not mount the instruments in or above the filling stream. Make sure that you detect the product surface, not the inflowing product.

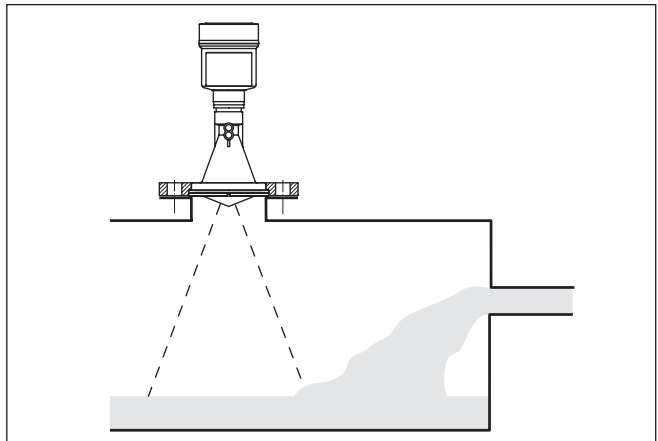

Fig. 8: Mounting of the radar sensor with inflowing medium

Socket with encapsulated antenna system

The socket piece should be dimensioned in such a way that the antenna end protrudes at least 10 mm (0.4 in) out of the socket.

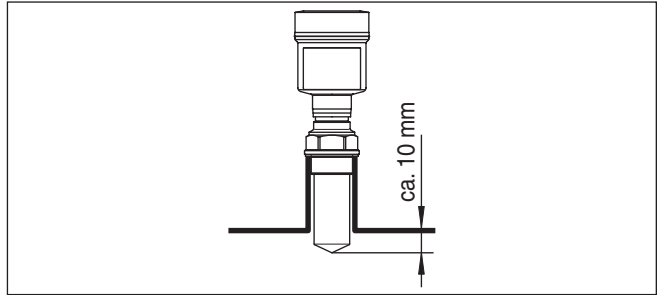

Fig. 9: Recommended socket mounting

If the reflective properties of the medium are good, you can mount VEGAPULS 61 on sockets which are higher than the length of the antenna. You will find recommended values for socket heights in the following illustration. The socket end should be smooth and burr-free, if possible also rounded. After installation you must carry out a false echo storage.

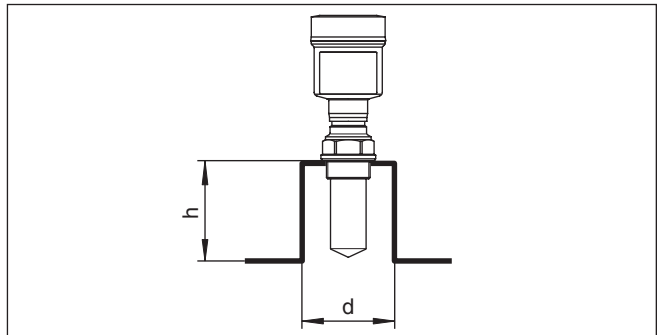

Fig. 10: Deviating socket dimensions

The below charts specify the max. socket length h depending on the diameter d .

Socket diameter d	Socket length h
40 mm	≤ 200 mm
50 mm	≤ 250 mm
80 mm	≤ 300 mm
100 mm	≤ 400 mm
150 mm	≤ 500 mm

Socket diameter d	Socket length h
1½"	≤ 7.9 in
2"	≤ 9.9 in
3"	≤ 11.8 in

Socket diameter d	Socket length h
4"	≤ 15.8 in
6"	≤ 19.7 in

Socket with plastic horn antenna

A corresponding collar flange for DN 80 (ASME 3" or JIS 80) as well as a suitable adapter flange are available for mounting VEGAPULS 61.

With the housing versions plastic, aluminium single chamber and stainless steel, the collar flange can be placed directly over the housing. With the aluminium double chamber housing, retroactive mounting in this way is not possible - the mounting type must be specified with the order.



Information:

The mounting socket should be as short as possible and its end rounded. This reduces false echoes from the vessel mounting socket.

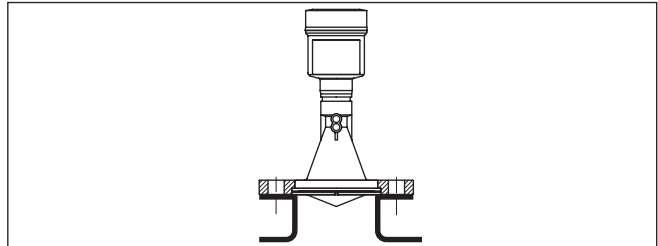
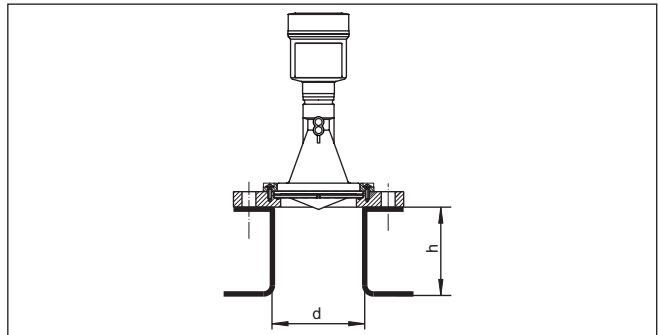

Fig. 11: Recommended socket mounting

If the medium has good reflective properties, VEGAPULS 61 can also be mounted on a longer socket piece. Recommended values for socket heights are specified in the following illustration. You must carry out a false echo storage afterwards.



The below charts specify the max. socket length h depending on the diameter d.

Socket diameter d	Socket length h
80 mm	≤ 300 mm

Socket diameter d	Socket length h
100 mm	≤ 400 mm
150 mm	≤ 500 mm

Socket diameter d	Socket length h
3"	≤ 11.8 in
4"	≤ 15.8 in
6"	≤ 19.7 in

Sensor orientation

In liquids, direct the sensor as perpendicular as possible to the product surface to achieve optimum measurement results.

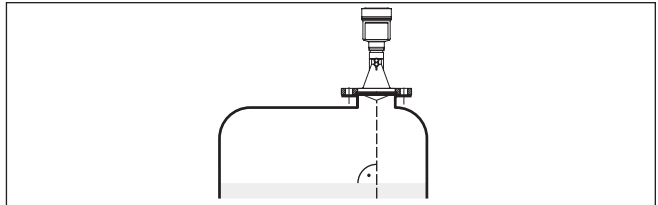

Fig. 13: Alignment in liquids

Vessel installations

The mounting location of the radar sensor should be a place where no other equipment or fixtures cross the path of the radar signals.

Vessel installations, such as e.g. ladders, limit switches, heating spirals, struts, etc., can cause false echoes and impair the useful echo. Make sure when planning your measuring point that the radar sensor has a "clear view" to the measured product.

In case of existing vessel installations, a false echo storage should be carried out during setup.

If large vessel installations such as struts or supports cause false echoes, these can be attenuated through supplementary measures. Small, inclined sheet metal baffles above the installations scatter the radar signals and prevent direct interfering reflections.

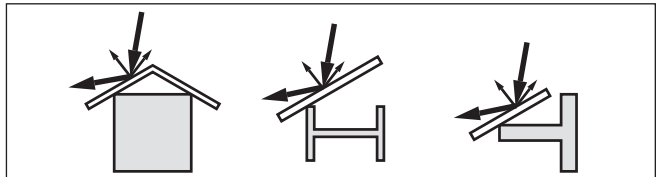

Fig. 14: Cover flat, large-area profiles with deflectors

Agitators

If there are agitators in the vessel, a false signal storage should be carried out with the agitators in motion. This ensures that the interfering reflections from the agitators are saved with the blades in different positions.

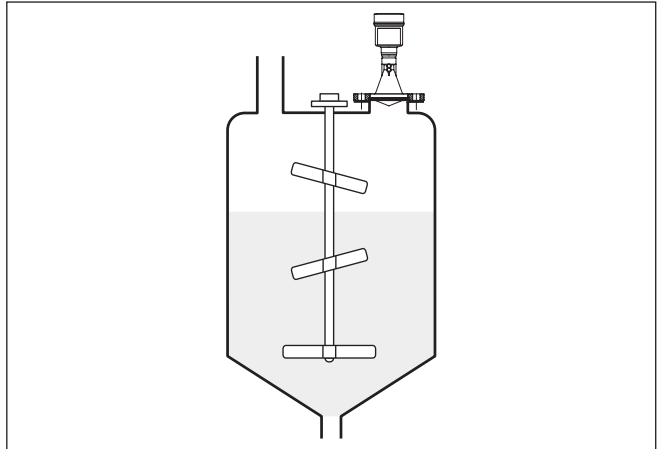

Fig. 15: Agitators

Foam generation

Through the action of filling, stirring and other processes in the vessel, compact foams that considerably damp the emitted signals may form on the product surface.

If foams are causing measurement errors, the biggest possible radar antennas, the electronics with increased sensitivity or low frequency radar sensors (C band) should be used.

As an alternative, sensors with guided microwave can be used. These are unaffected by foam generation and are best suited for such applications.

Measurement in a surge pipe

By using a surge pipe in the vessel, the influence of vessel installations and turbulence can be excluded. Under these prerequisites, the measurement of products with low dielectric values (ϵ_r value ≤ 1.6) is possible.

Note the following illustrations and instructions for measurement in a surge pipe.



Information:

Measurement in a surge pipe is not recommended for extremely adhesive products.

Configuration surge pipe

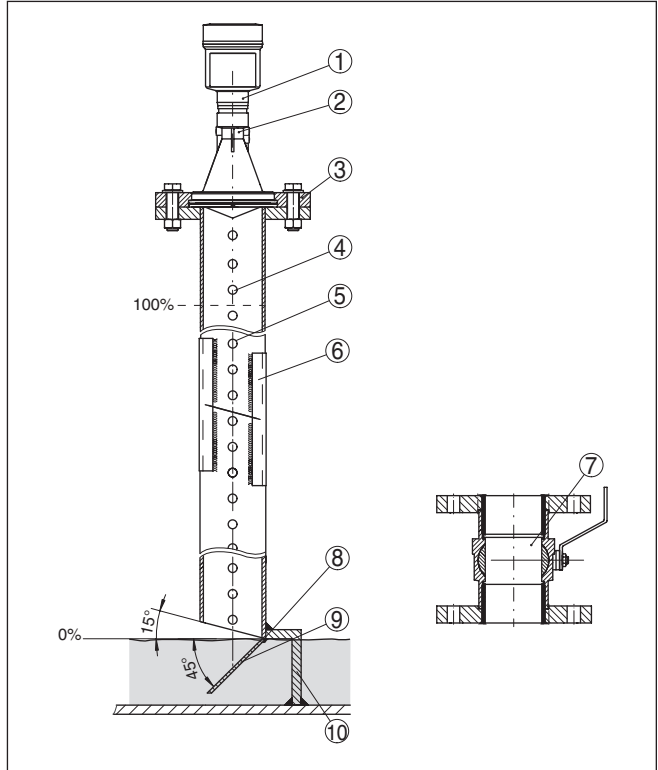

Fig. 16: Configuration surge pipe VEGAPULS 61

- 1 Radar sensor
- 2 Polarisation marking
- 3 Thread or flange on the instrument
- 4 Vent hole
- 5 Holes
- 6 Welding connection through U-profile
- 7 Ball valve with complete opening
- 8 Surge pipe end
- 9 Reflector sheet
- 10 Fastening of the surge pipe

Surge pipe extension

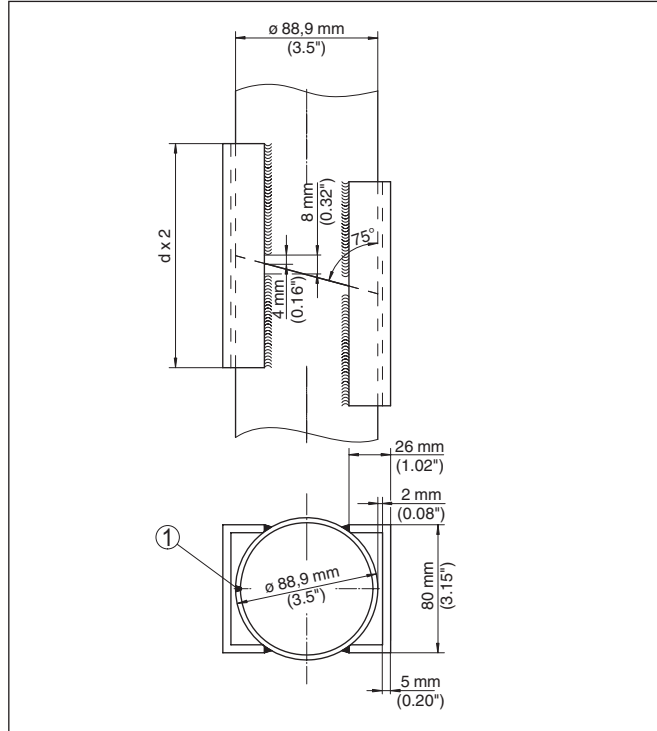

Fig. 17: Welding connection with surge pipe extension for different example diameters

1 Position of the welded joint with longitudinally welded pipes

Instructions and requirements, surge pipe

Instructions of orientation of the polarisation:

- Note marking of the polarisation on the sensor
- With threaded versions, the marking is on the hexagon, with flange versions between two flange holes
- The marking must be in one plane with the holes in the surge pipe

Instructions for the measurement:

- The 100 % point must be below the upper vent hole and the antenna edge
- The 0 % point is the end of the surge pipe
- During parameter adjustment, select "Application standpipe" and enter the tube diameter to compensate for errors due to running time shift
- A false signal suppression with the installed sensor is recommended but not mandatory
- The measurement through a ball valve with unrestricted channel is possible

Constructive requirements:

- Material metal, smooth inner surface
- Preferably pultruded or straight beaded stainless steel tube
- Welded joint should be straight and lie in one axis with the holes
- Flanges are welded to the tube according to the orientation of the polarisation
- When using a ball valves, align the transitions on the inside and fix accurately
- Gap size with junctions ≤ 0.1 mm
- Surge pipes must extend all the way down to the requested min. level, as measurement is only possible within the tube
- Diameter of holes ≤ 5 mm, any number OK, on one side or completely through
- The antenna diameter of the sensor should correspond to the inner diameter of the tube
- Diameter should be constant over the complete length

Instructions for surge pipe extension:

- The ends of the extension tubes must be bevelled and exactly aligned
- Welded connection via external U profiles according to illustration above. Length of the U profiles should be at least double the tube diameter
- Do not weld through the pipe wall. The surge pipe must remain smooth inside. Roughness and beads on the inside caused by unintentional penetration should be removed since they cause strong false echoes and encourage buildup
- An extension via welding neck flanges or pipe collars is not recommended.

Measurement in the bypass tube

An alternative to measurement in a surge pipe is measurement in a bypass tube outside of the vessel.

Configuration bypass

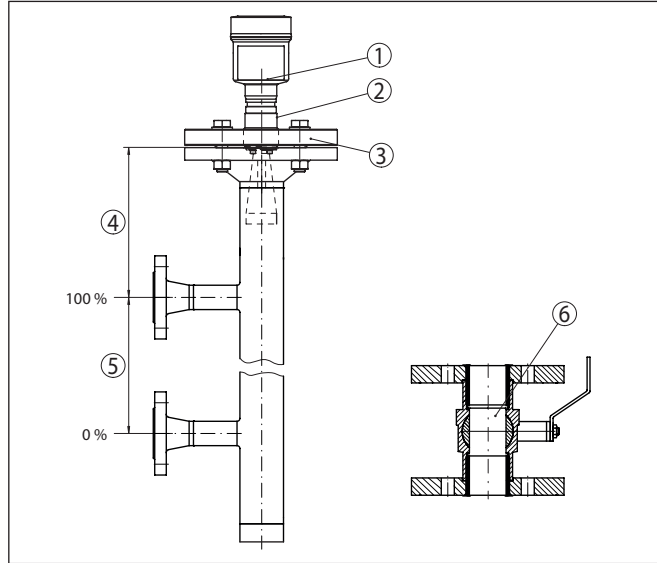

Fig. 18: Configuration bypass

- 1 Radar sensor
- 2 Polarisation marking
- 3 Instrument flange
- 4 Distance sensor reference plane to upper tube connection
- 5 Distance of the tube connections
- 6 Ball valve with complete opening

Instructions and requirements, bypass

Instructions of orientation of the polarisation:

- Note marking of the polarisation on the sensor
- With threaded versions, the marking is on the hexagon, with flange versions between two flange holes
- The marking must be in one plane with the tube connections to the vessel

Instructions for the measurement:

- The 100 % point may not be above the upper tube connection to the vessel
- The 0 % point may not be below the lower tube connection to the vessel
- Min. distance, sensor reference plane to upper edge of upper tube connection > 300 mm
- During parameter adjustment, select "Application standpipe" and enter the tube diameter to compensate for errors due to running time shift
- A false signal suppression with the installed sensor is recommended but not mandatory
- The measurement through a ball valve with unrestricted channel is possible

Constructional requirements on the bypass pipe:

- Material metal, smooth inner surface
- In case of an extremely rough tube inner surface, use an inserted tube (tube in tube) or a radar sensor with tube antenna
- Flanges are welded to the tube according to the orientation of the polarisation
- Gap size with junctions ≤ 0.1 mm, for example, when using a ball valve or intermediate flanges with single pipe sections
- The antenna diameter of the sensor should correspond to the inner diameter of the tube
- Diameter should be constant over the complete length

4.6 Measurement setup - Flow**Flow measurement with rectangular flume**

The short examples give you introductory information on the flow measurement. Detailed planning information is available from flume manufacturers and in special literature.

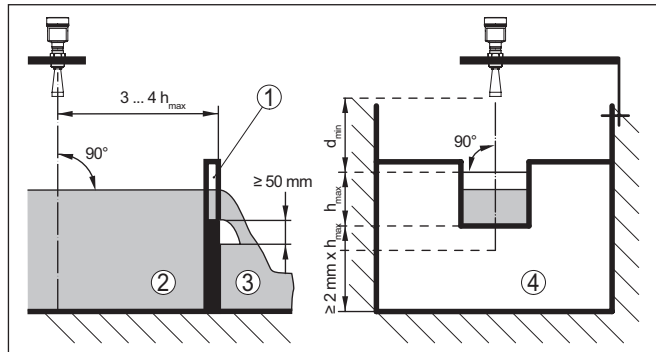

Fig. 19: Flow measurement with rectangular flume: d_{min} = min. distance of the sensor (see chapter "Technical data"); h_{max} = max. filling of the rectangular flume

- 1 Overflow orifice (side view)
- 2 Headwater
- 3 Tail water
- 4 Overfall orifice (view from bottom water)

In general, the following points must be observed:

- Install the sensor on the headwater side
- Installation in the centre of the flume and vertical to the liquid surface
- Distance to the overflow orifice
- Distance of orifice opening above ground
- Min. distance of the orifice opening to bottom water
- Min. distance of the sensor to max. storage level

Flow measurement with Khafagi Venturi flume

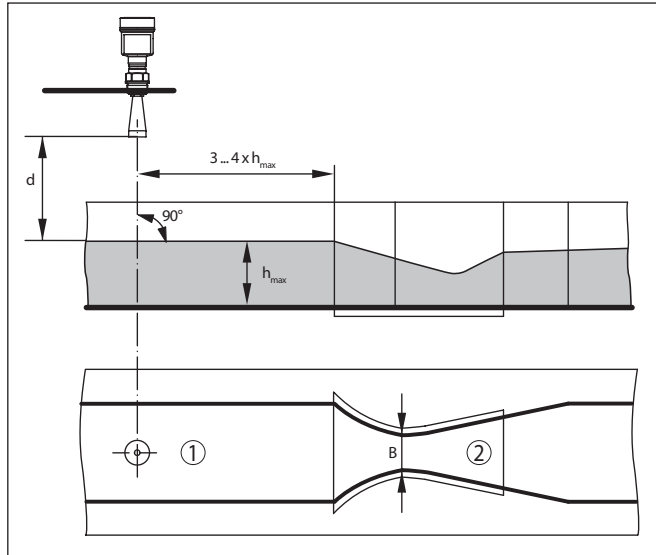

Fig. 20: Flow measurement with Khafagi-Venturi flume: d = Min. distance to sensor; h_{max} = max. filling of the flume; B = tightest constriction in the flume

- 1 Position sensor
- 2 Venturi flume

In general, the following points must be observed:

- Installation of the sensor at the inlet side
- Installation in the centre of the flume and vertical to the liquid surface
- Distance to the Venturi flume
- Min. distance of the sensor to max. storage level

5 Connecting to power supply

5.1 Preparing the connection

Safety instructions

Always keep in mind the following safety instructions:



Warning:

Connect only in the complete absence of line voltage.

- The electrical connection must only be carried out by trained personnel authorised by the plant operator.
- If overvoltage surges are expected, overvoltage arresters should be installed.

Voltage supply

Power supply and current signal are carried on the same two-wire cable. The operating voltage can differ depending on the instrument version.

The data for power supply are specified in chapter "*Technical data*".

Provide a reliable separation between the supply circuit and the mains circuits according to DIN EN 61140 VDE 0140-1.

Keep in mind the following additional factors that influence the operating voltage:

- Lower output voltage of the power supply unit under nominal load (e.g. with a sensor current of 20.5 mA or 22 mA in case of fault)
- Influence of additional instruments in the circuit (see load values in chapter "*Technical data*")

Connection cable

The instrument is connected with standard two-wire cable without screen. If electromagnetic interference is expected which is above the test values of EN 61326-1 for industrial areas, screened cable should be used.

Use cable with round cross section for instruments with housing and cable gland. To ensure the seal effect of the cable gland (IP protection rating), find out which cable outer diameter the cable gland is suitable for.

Use a cable gland fitting the cable diameter.

We generally recommend the use of screened cable for HART multi-drop mode.

Cable gland ½ NPT

With plastic housing, the NPT cable gland or the Conduit steel tube must be screwed without grease into the threaded insert.

Max. torque for all housings see chapter "*Technical data*".

Cable screening and grounding

If screened cable is required, we recommend connecting the cable screen on both ends to ground potential. In the sensor, the screen must be connected directly to the internal ground terminal. The ground terminal on the outside of the housing must be connected to the ground potential (low impedance).

In Ex systems, the grounding is carried out according to the installation regulations.

5.2 Connecting

Connection technology

The voltage supply and signal output are connected via the spring-loaded terminals in the housing.

Connection to the display and adjustment module or to the interface adapter is carried out via contact pins in the housing.



Information:

The terminal block is pluggable and can be removed from the electronics. To do this, lift the terminal block with a small screwdriver and pull it out. When reinserting the terminal block, you should hear it snap in.

Connection procedure

Proceed as follows:

1. Unscrew the housing lid
2. If a display and adjustment module is installed, remove it by turning it slightly to the left.
3. Loosen compression nut of the cable entry gland
4. Remove approx. 10 cm (4 in) of the cable mantle, strip approx. 1 cm (0.4 in) of insulation from the ends of the individual wires
5. Insert the cable into the sensor through the cable entry



Fig. 21: Connection steps 5 and 6 - Single chamber housing



Fig. 22: Connection steps 5 and 6 - Double chamber housing

6. Insert the wire ends into the terminals according to the wiring plan



Information:

Solid cores as well as flexible cores with wire end sleeves are inserted directly into the terminal openings. In case of flexible cores without end sleeves, press the terminal from above with a small screwdriver, the terminal opening is then free. When the screwdriver is released, the terminal closes again.

You can find further information on the max. wire cross-section under "*Technical data/Electromechanical data*"

7. Check the hold of the wires in the terminals by lightly pulling on them
8. Connect the screen to the internal ground terminal, connect the outer ground terminal to potential equalisation
9. Tighten the compression nut of the cable entry gland. The seal ring must completely encircle the cable
10. Reinsert the display and adjustment module, if one was installed
11. Screw the housing lid back on

The electrical connection is finished.

5.3 Wiring plan, single chamber housing



The following illustration applies to the non-Ex as well as to the Ex-ia version.

Electronics and terminal compartment

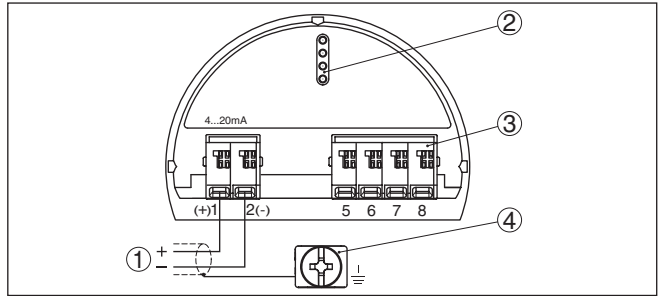

Fig. 23: Electronics and terminal compartment, single chamber housing

- 1 Voltage supply, signal output
- 2 For display and adjustment module or interface adapter
- 3 For external display and adjustment unit
- 4 Ground terminal for connection of the cable screen

5.4 Wiring plan, double chamber housing



The following illustrations apply to the non-Ex as well as to the Ex-ia version.

Electronics compartment

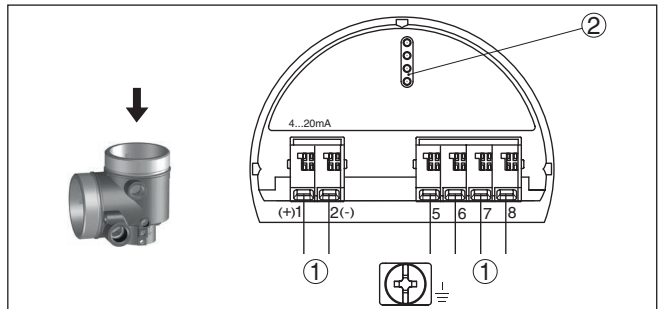

Fig. 24: Electronics compartment, double chamber housing

- 1 Internal connection to the terminal compartment
- 2 For display and adjustment module or interface adapter

Terminal compartment

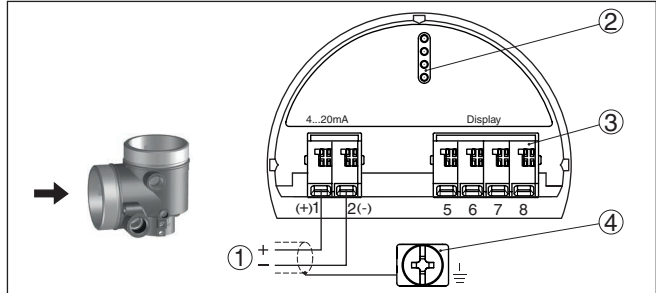

Fig. 25: Terminal compartment, double chamber housing

- 1 Voltage supply, signal output
- 2 For display and adjustment module or interface adapter
- 3 For external display and adjustment unit
- 4 Ground terminal for connection of the cable screen

**Information:**

Parallel use of an external display and adjustment unit and a display and adjustment module in the terminal compartment is not supported.

Terminal compartment
- Radio module PLICS-
MOBILE

Fig. 26: Terminal compartment, radio module PLICSMOBILE

- 1 Voltage supply

You can find detailed information on connection in the supplementary instructions "PLICSMOBILE GSM/GPRS radio module".

5.5 Wiring plan, double chamber housing Ex d ia

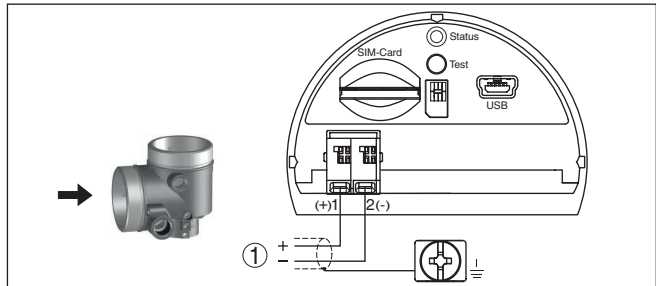
Electronics compartment

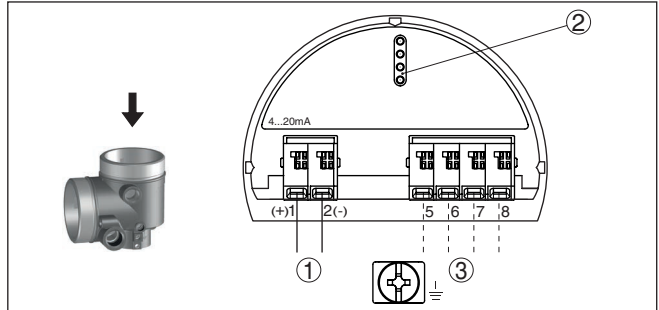

Fig. 27: Electronics compartment, double chamber housing Ex d ia

- 1 Internal connection to the terminal compartment
- 2 For display and adjustment module or interface adapter
- 3 Internal connection to the plug connector for external display and adjustment unit (optional)



Note:

HART multidrop mode is not possible when using an Ex-d-ia instrument.

Terminal compartment

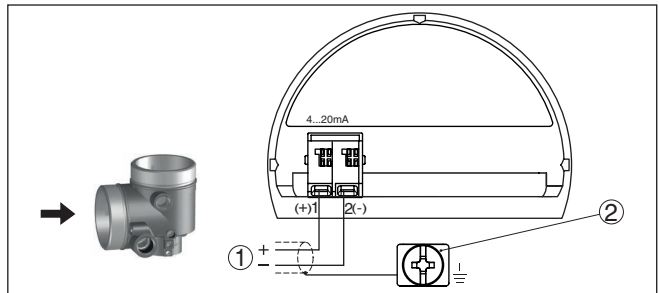

Fig. 28: Terminal compartment, double chamber housing Ex d ia

- 1 Voltage supply, signal output
- 2 Ground terminal for connection of the cable screen

Plug M12 x 1 for external display and adjustment unit

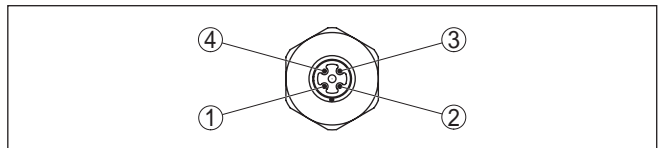

Fig. 29: Top view of the plug connector

- 1 Pin 1
- 2 Pin 2
- 3 Pin 3
- 4 Pin 4

Contact pin	Colour connection cable in the sensor	Terminal, electronics module
Pin 1	Brown	5
Pin 2	White	6
Pin 3	Blue	7
Pin 4	Black	8

5.6 Double chamber housing with DISADAPT

Electronics compartment

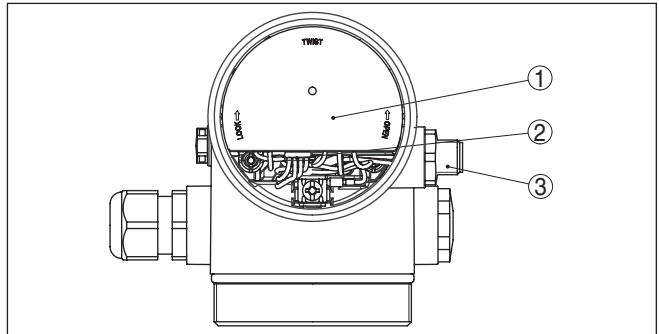

Fig. 30: View to the electronics compartment with DISADAPT for connection of the external display and adjustment unit

- 1 DISADAPT
- 2 Internal plug connection
- 3 Plug connector M12 x 1

Assignment of the plug connector

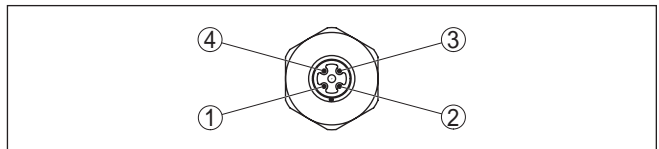

Fig. 31: View to the plug connector M12 x 1

- 1 Pin 1
- 2 Pin 2
- 3 Pin 3
- 4 Pin 4

Contact pin	Colour connection cable in the sensor	Terminal, electronics module
Pin 1	Brown	5
Pin 2	White	6
Pin 3	Blue	7
Pin 4	Black	8

Wire assignment, connection cable**5.7 Wiring plan - version IP 66/IP 68, 1 bar**

Fig. 32: Wire assignment in permanently connected connection cable

- 1 brown (+) and blue (-) to power supply or to the processing system
- 2 Shielding

5.8 Switch-on phase

After connecting the instrument to power supply or after a voltage recurrence, the instrument carries out a self-check for approx. 30 s:

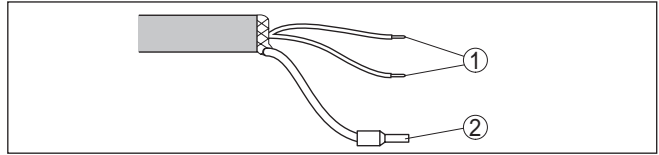
- Internal check of the electronics
- Indication of the instrument type, hardware and software version, measurement loop name on the display or PC
- Indication of the status message "*F 105 Determine measured value*" on the display or PC
- The output signal jumps to the set fault current

As soon as a plausible measured value is found, the corresponding current is outputted to the signal cable. The value corresponds to the actual level as well as the settings already carried out, e.g. factory setting.

6 Set up with the display and adjustment module

6.1 Insert display and adjustment module

The display and adjustment module can be inserted into the sensor and removed again at any time. You can choose any one of four different positions - each displaced by 90°. It is not necessary to interrupt the power supply.

Proceed as follows:

1. Unscrew the housing lid
2. Place the display and adjustment module on the electronics in the desired position and turn it to the right until it snaps in.
3. Screw housing lid with inspection window tightly back on

Disassembly is carried out in reverse order.

The display and adjustment module is powered by the sensor, an additional connection is not necessary.



Fig. 33: Installing the display and adjustment module in the electronics compartment of the single chamber housing

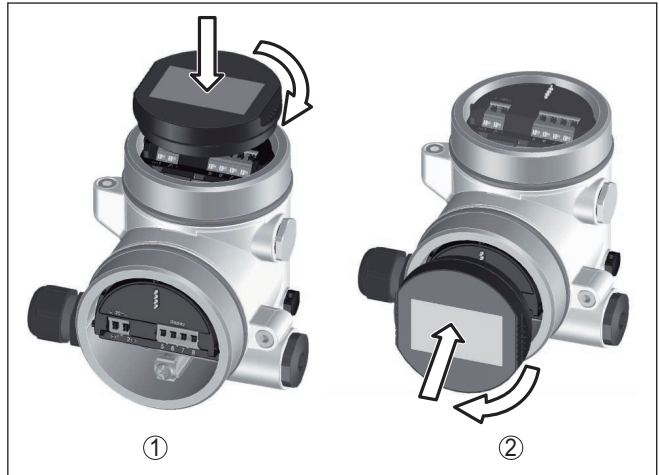

Fig. 34: Installing the display and adjustment module in the double chamber housing

- 1 In the electronics compartment
- 2 In the terminal compartment



Note:

If you intend to retrofit the instrument with a display and adjustment module for continuous measured value indication, a higher lid with an inspection glass is required.

6.2 Adjustment system

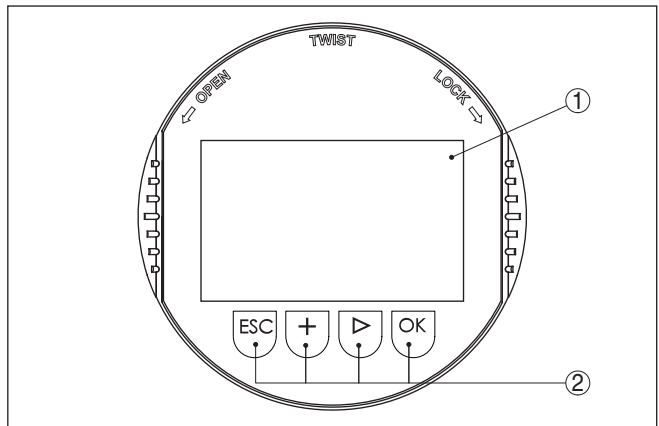

Fig. 35: Display and adjustment elements

- 1 LC display
- 2 Adjustment keys

Key functions

- **[OK]** key:

- Move to the menu overview
- Confirm selected menu
- Edit parameter
- Save value
- **[->]** key:
 - Presentation, change measured value
 - Select list entry
 - Select menu items in the quick setup
 - Select editing position
- **[+]** key:
 - Change value of the parameter
- **[ESC]** key:
 - Interrupt input
 - Jump to next higher menu

Adjustment system

You adjust the instrument via the four keys of the display and adjustment module. The individual menu items are shown on the LC display. You can find the functions of the individual keys in the previous illustration.

Time functions

By pushing the **[+]** and **[->]** keys once, the edited value or the cursor changes by one position. By pushing the keys longer than 1 s the change will be continuously.

By pushing the **[OK]** and **[ESC]** keys simultaneously for more than 5 s, a return to the basic menu is caused. The menu language is then switched over to "English".

Approx. 60 minutes after the last pressing of a key, an automatic reset to measured value indication is triggered. Any values not confirmed with **[OK]** will not be saved.

6.3 Measured value indication - Selection national language

Measured value indication

With the **[->]** key you move between three different indication modes.

In the first view, the selected measured value is displayed in large digits.

In the second view, the selected measured value and a corresponding bar graph presentation are displayed.

In the third view, the selected measured value as well as a second selectable value, e.g. the temperature of the electronics, are displayed.

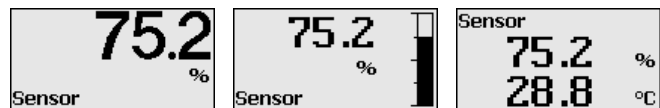

During the initial setup of an instrument shipped Ex works, use the "OK" key to get to the menu "National language".

Selection of national language

This menu item is used to select the national language for further parameter adjustment. You can change the selection via the menu item "Setup - Display, Menu language".



With the "OK" key you move to the main menu.

6.4 Parameter adjustment

The instrument is adapted to the application conditions via the parameter adjustment. The parameter adjustment is carried out with an adjustment menu.

Main menu

The main menu is divided into five sections with the following functions:

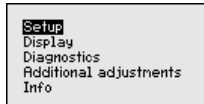

Setup: Settings, e.g., for measurement loop name, medium, application, vessel, adjustment, signal output

Display: Settings, e.g., for language, measured value display, lighting

Diagnosis: Information, e.g. on instrument status, pointer, measurement certainty, simulation, echo curve

Further settings: Instrument unit, false signal suppression, linearisation curve, reset, date/time, reset, copy function

Info: Instrument name, hardware and software version, date of manufacture, instrument features



Information:

In this operating instructions manual, the instrument-specific parameters in the menu sections "Setup", "Diagnosis" and "Additional settings" are described. The general parameters in these menu section are described in the operating instructions manual "Indicating and adjustment module".

You can find in the operating instructions manual "Display and adjustment module" also the description of the menu sections "Display" and "Info".

In the main menu point "Setup", the individual submenu points should be selected one after the other and provided with the correct parameters to ensure optimum adjustment of the measurement. The procedure is described in the following.

Setup - Measurement loop name

In the menu item "Sensor TAG" you edit a twelve digit measurement loop designation label.

You can enter an unambiguous designation for the sensor, e.g. the measurement loop name or the tank or product designation. In digital systems and in the documentation of larger plants, a singular design-

nation must be entered for exact identification of individual measuring points.

The available digits comprise:

- Letters from A ... Z
- Numbers from 0 ... 9
- Special characters +, -, /, -

Setup Display Diagnostics Additional adjustments Info	Setup Measurement loop name Medium Application Vessel type Vessel height/Me. range	Setup Measurement loop name Units Probe length Application Adjustment level
Measurement loop name Sensor		

Setup - Medium

Each medium has different reflection properties. With liquids, further interfering factors are fluctuation product surface and foam generation. With bulk solids, these are dust generation, material cone and additional echoes from the vessel wall.

To adapt the sensor to these different measuring conditions, the selection "*Liquid*" or "*Bulk solid*" should be made in this menu item.

Setup Measurement loop name Medium Application Vessel type Vessel height/Me. range	Medium Liquid Water based	Solvent Chem. mixtures <input checked="" type="checkbox"/> Water based
Medium Solid Ballast/pebbles	Medium Powder/dust Granules/pellets <input checked="" type="checkbox"/> Ballast/pebbles	

Through this selection, the sensor is adapted perfectly to the product and measurement reliability, particularly in products with poor reflective properties, is considerably increased.

Enter the requested parameters via the appropriate keys, save your settings with **[OK]** and jump to the next menu item with the **[ESC]** and the **[->]** key.

Setup - Application

In addition to the medium, also the application, i.e. the measuring site, can influence the measurement.

With this menu item, the sensor can be adapted to the applications. The adjustment possibilities depend on the selection "*Liquid*" or "*Bulk solid*" under "*Medium*".

Setup Measurement loop name Medium Application Vessel type Vessel height/Me. range

The following options are available when "*Liquid*" is selected:

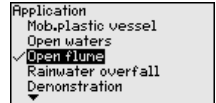
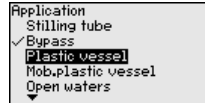
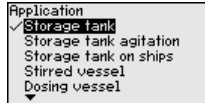

The selection "Standpipe" opens a new window in which the inner diameter of the applied standpipe is entered.

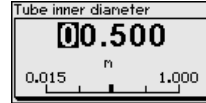
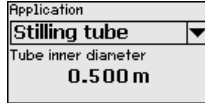

The following features form the basis of the applications:

Storage tank:

- Setup: large-volumed, upright cylindrical, spherical
- Product speed: slow filling and emptying
- Process/measurement conditions:
 - Condensation
 - Smooth product surface
 - High requirements to the measurement accuracy
- Properties, sensor:
 - Slight sensitivity against sporadic false echoes
 - Stable and reliable measured values through averaging
 - High accuracy
 - Short reaction time of the sensor not required

Storage tank with product circulation:

- Setup: large-volumed, upright cylindrical, spherical
- Product speed: slow filling and emptying
- Installations: small laterally mounted or large top mounted stirrer
- Process/measurement conditions:
 - Relatively smooth product surface
 - High requirements to the measurement accuracy
 - Condensation
 - Slight foam generation
 - Overfilling possible
- Properties, sensor:
 - Slight sensitivity against sporadic false echoes
 - Stable and reliable measured values through averaging
 - High accuracy because not adjusted for max. speed
 - False signal suppression recommended

Storage tank on ships (Cargo Tank):

- Product speed: slow filling and emptying
- Vessel:
 - Installations in the bottom section (bracers, heating spirals)
 - High sockets 200 ... 500 mm, also with large diameters
- Process/measurement conditions:
 - Condensation, buildup by movement
 - Max. requirement on measurement accuracy from 95 %
- Properties, sensor:
 - Slight sensitivity against sporadic false echoes
 - Stable and reliable measured values through averaging

- High accuracy
- False signal suppression required

Stirrer vessel (reactor):

- Setup: all vessel sizes possible
- Product speed:
 - Fast to slow filling possible
 - Vessel is very often filled and emptied
- Vessel:
 - Socket available
 - Large agitator blades of metal
 - Vortex breakers, heating spirals
- Process/measurement conditions:
 - Condensation, buildup by movement
 - Strong spout generation
 - Very agitated surface, foam generation
- Properties, sensor:
 - Higher measurement speed through lower averaging
 - Sporadic false echoes are suppressed

Dosing vessel:

- Setup: all vessel sizes possible
- Product speed:
 - Fast filling and emptying
 - Vessel is very often filled and emptied
- Vessel: narrow installation situation
- Process/measurement conditions:
 - Condensation, buildup on the antenna
 - Foam generation
- Properties, sensor:
 - Measurement speed optimized by virtually no averaging
 - Sporadic false echoes are suppressed
 - False signal suppression recommended

Standpipe:

- Product speed: very fast filling and emptying
- Vessel:
 - Vent hole
 - Joins like flanges, weld joints
 - Shifting of the running time in the tube
- Process/measurement conditions:
 - Condensation
 - Buildup
- Properties, sensor:
 - Measurement speed optimized through little averaging
 - Entering the tube inside diameter takes the running time shift into consideration
 - Echo detection sensitivity reduced

Bypass:

- Product speed:
 - Fast up to slow filling with short up to long bypass tube possible
 - Often the level is hold via a control facility

- Vessel:
 - Lateral outlets and inlets
 - Joins like flanges, weld joints
 - Shifting of the running time in the tube
- Process/measurement conditions:
 - Condensation
 - Buildup
 - Separation of oil and water possible
 - Overflowing into the antenna possible
- Properties, sensor:
 - Measurement speed optimized through little averaging
 - Entering the tube inside diameter takes the running time shift into consideration
 - Echo detection sensitivity reduced
 - False signal suppression recommended

Plastic tank:

- Vessel:
 - Measurement fix mounted or integrated
 - Measurement depending on the application through the vessel top
 - With empty vessel, the measurement can be carried out through the bottom
- Process/measurement conditions:
 - Condensation on the plastic ceiling
 - In outside facilities water and snow on the vessel top possible
- Properties, sensor:
 - False signals outside the vessel are not taken into consideration
 - False signal suppression recommended

Transportable plastic tank:

- Vessel:
 - Material and thickness different
 - Measurement through the vessel top
- Process/measurement conditions:
 - Measured value jump with vessel change
- Properties, sensor:
 - Quick adaptation to changing reflection conditions through vessel change
 - False signal suppression required

Open water (gauge measurement):

- Gauge rate of change: slow gauge change
- Process/measurement conditions:
 - Distance sensor to water surface to big
 - Extreme damping of output signal due to wave generation
 - Ice and condensation on the antenna possible
 - Spiders and insect nestle in the antennas
 - Floating material and animals sporadically on the water surface
- Properties, sensor:
 - Stable and reliable measured values through high averaging
 - Insensitive in the close range

Open flume (flow measurement):

- Gauge rate of change: slow gauge change
- Process/measurement conditions:
 - Ice and condensation on the antenna possible
 - Spiders and insect nestle in the antennas
 - Smooth water surface
 - Exact measurement result required
 - Distance to the water surface normally relatively high
- Properties, sensor:
 - Stable and reliable measured values through high averaging
 - Insensitive in the close range

Rain water overfall (weir):

- Gauge rate of change: slow gauge change
- Process/measurement conditions:
 - Ice and condensation on the antenna possible
 - Spiders and insect nestle in the antennas
 - Turbulent water surface
 - Sensor flooding possible
- Properties, sensor:
 - Stable and reliable measured values through high averaging
 - Insensitive in the close range

Demonstration:

- Adjustment for all applications which are not typically level measurement
 - Instrument demonstration
 - Object recognition/monitoring (additional settings required)
- Properties, sensor:
 - Sensor accepts all measured value changes within the measuring range immediately
 - High sensitivity against interferences, because virtually no averaging

**Caution:**

If liquids with different dielectric constants separate in the vessel, for example through condensation, the radar sensor can detect under certain circumstances only the medium with the higher dielectric constant. Keep in mind that layer interfaces can cause faulty measurements.

If you want to measure the total height of both liquids reliably, please contact our service department or use an instrument specially designed for interface measurement.

The following options are available when "Bulk solid" is selected:

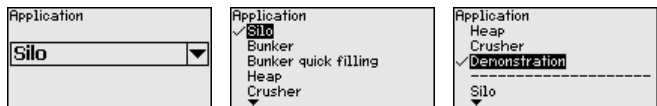

The following features form the basis of the applications:

Silo (slender and high):

- Vessel of metal: weld joints
- Process/measurement conditions:
 - Filling aperture too close to the sensor
 - System noise in completely empty silo increased
- Properties, sensor:
 - Stable measured values through higher averaging
 - False signal suppression during setup recommended, required for automatic false signal suppression
 - Automatic false signal suppression with partly filled vessel

Bunker (large-volume):

- Vessel of concrete or metal:
 - Structured vessel walls
 - Installations present
- Process/measurement conditions:
 - Large distance to the medium
 - Large angles of repose
- Properties, sensor:
 - Mean averaging
 - High measured value jumps are accepted

Bunker with fast filling:

- Vessel of concrete or metal, also multiple chamber silo:
 - Structured vessel walls
 - Installations present
- Process/measurement conditions:
 - Measured value jumps, e.g. through truck loading
 - Large distance to the medium
 - Large angles of repose
- Properties, sensor:
 - Lower averaging
 - Very high measured value jumps are accepted

Heap:

- Sensor mounting on movable conveyor belts
- Detection of the heap profile
- Height detection during filling
- Process/measurement conditions:
 - Measured value jumps, e.g. by the profile of the heap or traverses
 - Large angles of repose
 - Measurement near the filling stream
- Properties, sensor:
 - Mean averaging
 - High measured value jumps are accepted

Crusher:

- Vessel: installations, wear and protective facilities available
- Process/measurement conditions:
 - Measured value jumps, e.g. through truck loading
 - Fast reaction time
 - Large distance to the medium

- Properties, sensor:
 - Little averaging
 - Max. reaction speed, very high measured value jumps are accepted

Demonstration:

- Adjustment for all applications which are not typically level measurement
 - Instrument demonstration
 - Object recognition/monitoring (additional settings required)
- Properties, sensor:
 - Sensor accepts all measured value changes within the measuring range immediately
 - High sensitivity against interferences, because virtually no averaging

Through this selection, the sensor is adapted optimally to the application or the location and measurement reliability under the various basic conditions is increased considerably.

Enter the requested parameters via the appropriate keys, save your settings with **[OK]** and jump to the next menu item with the **[ESC]** and the **[->]** key.

Setup - Vessel form

Also the vessel form can influence the measurement apart from the medium and the application. To adapt the sensor to these measurement conditions, this menu item offers you different options for vessel bottom and ceiling in case of certain applications.



Enter the requested parameters via the appropriate keys, save your settings with **[OK]** and jump to the next menu item with the **[ESC]** and the **[->]** key.

Setup - Vessel height, measuring range

With this selection, the operating range of the sensor is adapted to the vessel height and the reliability with different frame conditions is increased considerably.

The min. adjustment must be carried out independently of this.



Enter the requested parameters via the appropriate keys, save your settings with **[OK]** and jump to the next menu item with the **[ESC]** and the **[->]** key.

Setup - Adjustment

Since the radar sensor is a distance measuring instrument, the distance from the sensor to the product surface is measured. For indication of the real level, an allocation of the measured distance to the percentage height must be carried out.

To perform the adjustment, enter the distance with full and empty vessel, see the following example:

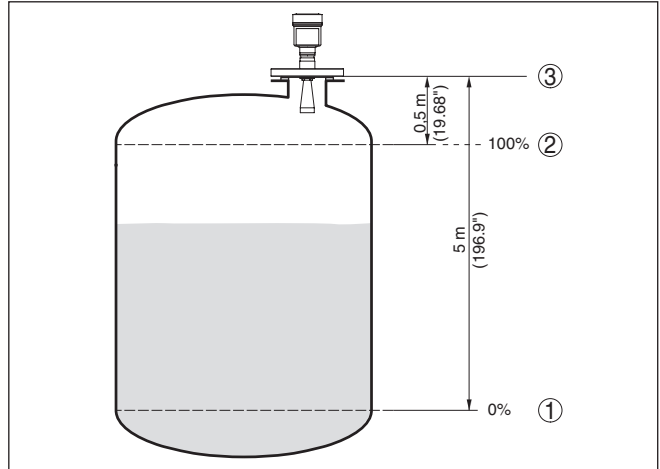

Fig. 36: Parameter adjustment example min./max. adjustment

- 1 Min. level = max. measuring distance
- 2 Max. level = min. measuring distance
- 3 Reference plane

If these values are not known, an adjustment with the distances of for example 10 % and 90 % is possible. Starting point for these distance specifications is always the seal surface of the thread or flange. You can find specifications of the reference plane in chapter "Technical data". By means of these settings, the real level will be calculated.

The real product level during this adjustment is not important, because the min./max. adjustment is always carried out without changing the product level. These settings can be made ahead of time without the instrument having to be installed.

Setup - Min. adjustment

Proceed as follows:

1. Select the menu item "Setup" with [->] and confirm with [OK]. Now select with [->] the menu item "Min. adjustment" and confirm with [OK].

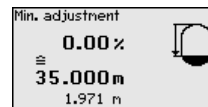
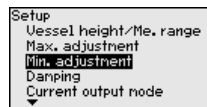

2. Edit the percentage value with [OK] and set the cursor to the requested position with [->].



- Set the requested percentage value with **[+]** and save with **[OK]**.
The cursor jumps now to the distance value.

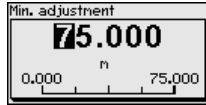

- Enter the suitable distance value in m for the empty vessel (e.g. distance from the sensor to the vessel bottom) corresponding to the percentage value.
- Save settings with **[OK]** and move with **[ESC]** and **[->]** to the max. adjustment.

Setup - Max. adjustment

Proceed as follows:

- Select with **[->]** the menu item Max. adjustment and confirm with **[OK]**.

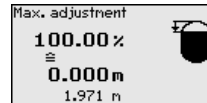
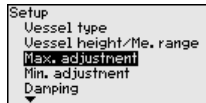

- Prepare the percentage value for editing with **[OK]** and set the cursor to the requested position with **[->]**.

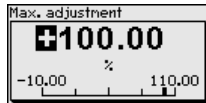

- Set the requested percentage value with **[+]** and save with **[OK]**.
The cursor jumps now to the distance value.

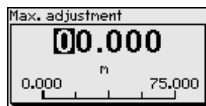

- Enter the appropriate distance value in m (corresponding to the percentage value) for the full vessel. Keep in mind that the max. level must lie below the min. distance to the antenna edge.
- Save settings with **[OK]**

Setup - Damping

To damp process-dependent measured value fluctuations, set an integration time of 0 ... 999 s in this menu item.

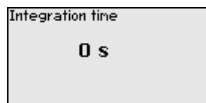
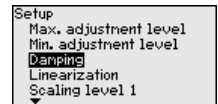
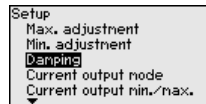
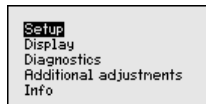

Depending on the sensor type, the factory setting is 0 s or 1 s.

Setup - Current output mode

In the menu item "Current output mode" you determine the output characteristics and reaction of the current output in case of failure.

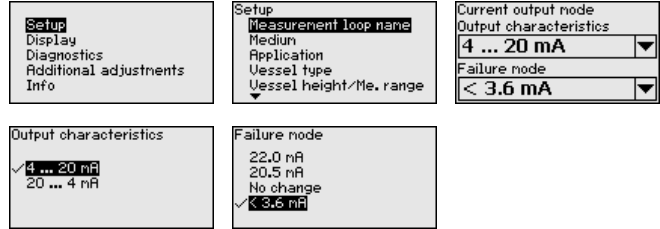

The default setting is output characteristics 4 ... 20 mA, failure mode < 3.6 mA.

Setup - Current output Min./Max.

In the menu item "Current output Min./Max.", you determine the reaction of the current output during operation.

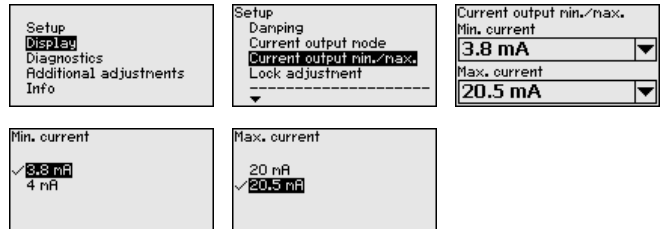

The default setting is min. current 3.8 mA and max. current 20.5 mA.

Lock setup - adjustment

In this menu item, the PIN is activated/deactivated permanently. Entering a 4-digit PIN protects the sensor data against unauthorized access and unintentional modifications. If the PIN is activated permanently, it can be deactivated temporarily (i.e. for approx. 60 min.) in any menu item.

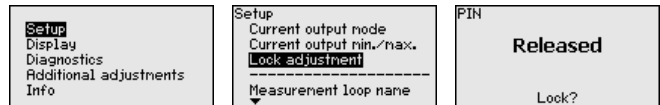

Only the following functions are permitted with activated PIN:

- Select menu items and show data
- Read data from the sensor into the display and adjustment module.



Caution:

With active PIN, adjustment via PACTware/DTM as well as other systems is also blocked.

In delivery status, the PIN is "0000".

Display - Language

This menu item enables the setting of the requested national language.

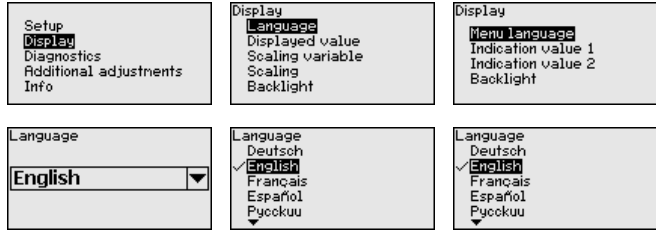

In the delivery status, the sensor is set to the ordered national language.

Display - Displayed value

In this menu item you can define the indication of the measured value on the display.

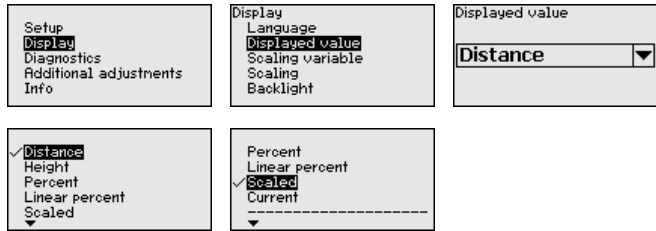

The default setting for the indication value is e.g. distance with radar sensors.

Display - Backlight

The optionally integrated background lighting can be adjusted via the adjustment menu. The function depends on the level of the supply voltage, see operating instructions of the respective sensor.

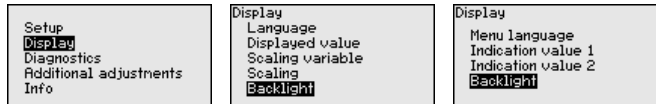

In delivery status, the lighting is switched on.

Diagnostics - Device status

In this menu item, the device status is displayed.

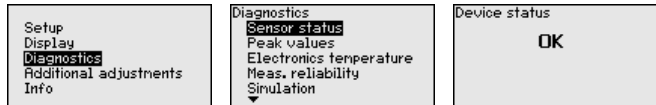

Diagnosis - Peak value

The respective min. and max. measured value is saved in the sensor. The values are displayed in the menu item "Peak values".

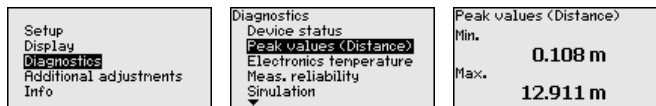

Diagnosis - Electronics temperature

The respective min. and max. measured value of the electronics temperature is saved in the sensor. These values as well as the actual temperature value are displayed in the menu item "Peak values".

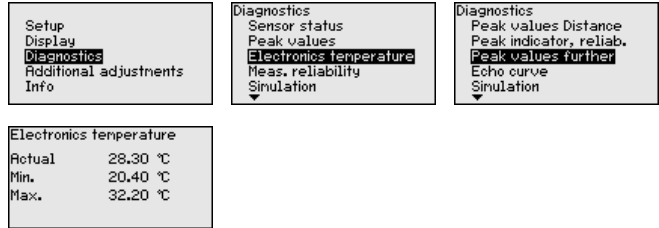

Diagnosis - Measurement reliability

When non-contact level sensors are used, the measurement can be influenced by the respective process conditions. In this menu item, the measurement reliability of the level echo is displayed as dB value. The measurement reliability equals signal strength minus noise. The higher the value, the more reliable the measurement. With a functioning measurement, the values are > 10 dB.

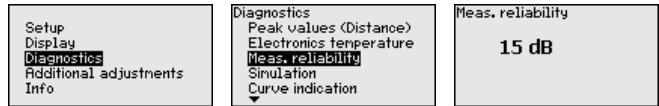

Diagnosis - Simulation

In this menu item you can simulate measured values via the current output. This allows the signal path to be tested, e.g. through downstream indicating instruments or the input card of the control system.

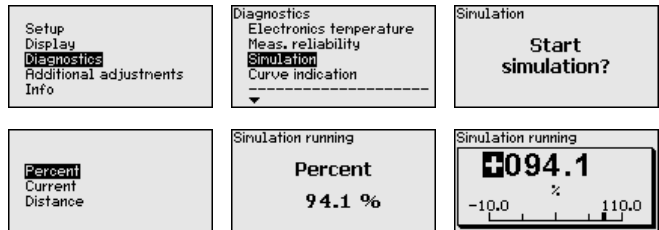

How to start the simulation:

1. Push **[OK]**
2. Select the requested simulation variable with **[>]** and confirm with **[OK]**.
3. With **[OK]** you start the simulation, first of all the actual measured value is displayed in %
4. Start the editing mode with **[OK]**
5. Set the requested numerical value with **[+]** and **[>]**.
6. Push **[OK]**



Note:

During simulation, the simulated value is outputted as 4 ... 20 mA current value and digital HART signal.

How to interrupt the simulation:

→ Push **[ESC]**



Information:

The simulation is automatically terminated 10 minutes after the last pressing of a key.

Diagnoses - Curve indication

The "Echo curve" shows the signal strength of the echoes over the measuring range in dB. The signal strength enables an evaluation of the quality of the measurement.

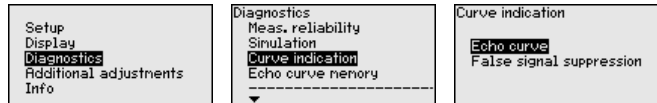

The "False signal suppression" displays the saved false echoes (see menu "Additional settings") of the empty vessel with signal strength in "dB" over the measuring range.

A comparison of echo curve and false signal suppression allows a more detailed statement of the reliability.



The selected curve is continuously updated. A submenu with zoom functions is opened with the **[OK]** key:

- "X-Zoom": Zoom function for the meas. distance
- "Y-Zoom": 1, 2, 5 and 10x signal magnification in "dB"
- "Unzoom": Reset the presentation to the nominal measuring range without magnification

Diagnoses - Echo curve memory

With the function "Echo curve memory" the echo curve can be saved at the time of setup. This is generally recommended; for using the Asset Management functions it is absolutely necessary. If possible, the curve should be saved with a low level in the vessel.

With the adjustment software PACTware and the PC, the high resolution echo curve can be displayed and used to recognize signal changes over the operating time. In addition, the echo curve of the setup can be also displayed in the echo curve window and compared with the actual echo curve.

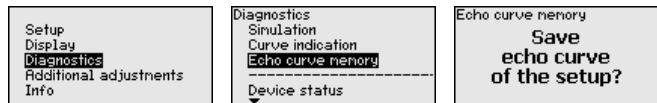

Additional adjustments - Device units

In this menu item you select the measured variable of the system and the temperature unit.

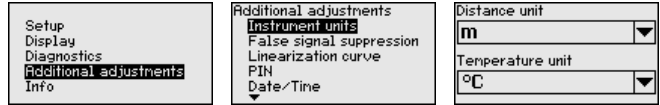

Additional adjustments - False signal suppression

The following circumstances cause interfering reflections and can influence the measurement:

- High sockets
- Vessel installations such as struts
- Agitators
- Buildup or welded joints on vessel walls



Note:

A false signal suppression detects, marks and saves these false signals so that they are no longer taken into account in the level measurement.

This should be done with a low level so that all potential interfering reflections can be detected.

Proceed as follows:

1. Select with **[>]** the menu item "False signal suppression" and confirm with **[OK]**.

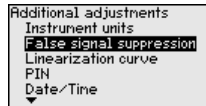

2. Confirm again with **[OK]**.

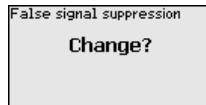

3. Confirm again with **[OK]**.

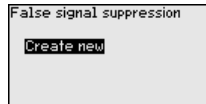

4. Confirm again with **[OK]** and enter the actual distance from the sensor to the product surface.

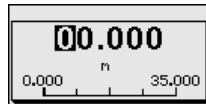

5. All interfering signals in this section are detected by the sensor and stored after confirming with **[OK]**.



Note:

Check the distance to the product surface, because if an incorrect (too large) value is entered, the existing level will be saved as a false signal. The level would then no longer be detectable in this area.

If a false signal suppression has already been saved in the sensor, the following menu window appears when selecting "*False signal suppression*":



Delete: An already created false signal suppression will be completely deleted. This is useful if the saved false signal suppression no longer matches the metrological conditions in the vessel.

Extend: is used to extend an already created false signal suppression. This is useful if a false signal suppression was carried out with a too high level and not all false signals could be detected. When selecting "*Extend*", the distance to the product surface of the created false signal suppression is displayed. This value can now be changed and the false signal suppression can be extended to this range.

Additional adjustments - Linearization curve

A linearization is necessary for all vessels in which the vessel volume does not increase linearly with the level - e.g. a horizontal cylindrical or spherical tank - and the indication or output of the volume is required. Corresponding linearization curves are preprogrammed for these vessels. They represent the correlation between the level percentage and vessel volume.

By activating the appropriate curve, the volume percentage of the vessel is displayed correctly. If the volume should not be displayed in percent but e.g. in l or kg, a scaling can be also set in the menu item "*Display*".

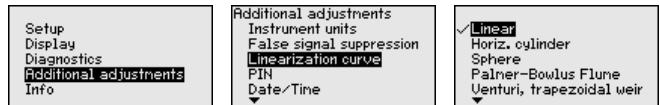

Enter the requested parameters via the appropriate keys, save your settings and jump to the next menu item with the **[ESC]** and **[->]** key.



Caution:

Note the following if instruments with appropriate approval are used as part of an overfill protection system according to WHG:

If a linearisation curve is selected, the measuring signal is no longer necessarily linear to the filling height. This must be considered by the user especially when adjusting the switching point on the limit signal transmitter.

Additional settings - PIN

Entering a 4-digit PIN protects the sensor data against unauthorized access and unintentional modification. In this menu item, the PIN is displayed or edited and changed. However, this menu item is only available if adjustment is enabled in the menu "*Setup*".

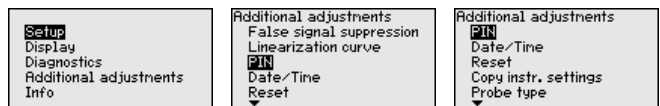

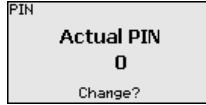

In delivery status, the PIN is "0000".

Additional adjustments - Date/Time

In this menu item, the internal clock of the sensor is adjusted.

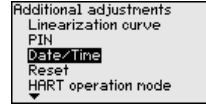
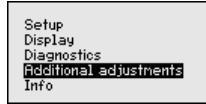

Additional adjustments - Reset

With a reset, certain parameter adjustments carried out by the user are reset.

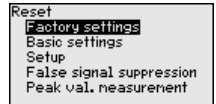
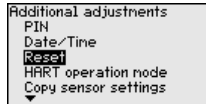

The following reset functions are available:

Delivery status: Restoring the parameter settings at the time of shipment from the factory incl. the order-specific settings. A created false signal suppression, user-programmable linearization curve as well as the measured value memory will be deleted.

Basic settings: Resetting of the parameter settings, incl. special parameters, to the default values of the respective instrument. Any stored false signal suppression or user programmable linearisation curve, as well as the measured value memory, is deleted.

Setup: Resetting of the parameter settings to the default values of the respective instrument in the menu item Setup. User-generated false signal suppression, user-programmed linearisation curve, measured value memory as well as event memory remain untouched. The linearisation is set to linear.

False signal suppression: Deleting a previously created false signal suppression. The false signal suppression created in the factory remains active.

Peak values, measured value: Resetting of the measured min. and max. distances to the actual measured value.

The following table shows the default values of the instrument. Depending on the instrument version, not all menu items are available or some may be differently assigned:

Menu	Menu item	Default value
Setup	Measurement loop name	Sensor
	Medium	Liquid/Water Bulk solids/Crushed stones, gravel
	Application	Storage tank Silo
	Vessel form	Vessel bottom, dished boiler end Vessel top, dished boiler end
	Vessel height/ Measuring range	Recommended measuring range, see " <i>Technical data</i> " in the supplement
	Min. adjustment	Recommended measuring range, see " <i>Technical data</i> " in the supplement
	Max. adjustment	0,000 m(d)
	Damping	0.0 s
	Current output mode	4 ... 20 mA, < 3.6 mA
	Current output Min./Max.	Min. current 3.8 mA, max. current 20.5 mA
	Lock adjustment	Released
	Display	Language
Displayed value		Distance
Display unit		m
Scaling size		Volume l
Scaling		0.00 lin %, 0 l 100.00 lin %, 100 l
Backlight		Switched on
Additional adjustments	Distance unit	m
	Temperature unit	°C
	Probe length	Length of the standpipe Ex factory
	Linearisation curve	Linear
	HART mode	Standard Address 0

Additional adjustments - HART mode

The sensor offers the HART modes standard and Multidrop. In this menu item you determine the HART modes and enter the address with Multidrop.

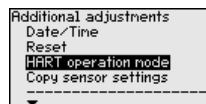
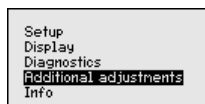

The mode standard with the fixed address 0 means output of the measured value as 4 ... 20 mA signal.

In Multidrop mode, up to 63 sensors can be operated on one two-wire cable. An address between 1 and 63 must be assigned to each sensor.¹⁾

The default setting is standard with address 0.

Additional adjustments - Copy instrument settings

The instrument settings are copied with this function. The following functions are available:

- Store data from the sensor into the indicating/adjustment module.
- Store data from the display and adjustment module in the sensor

The following data or settings for adjustment of the display and adjustment module are saved:

- All data of the menu "Setup" and "Display"
- In the menu "Additional settings" the items "Distance unit, temperature unit and linearization"
- The values of the user programmable linearization curve

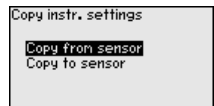
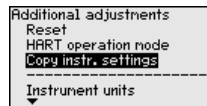
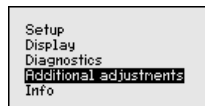

The copied data are permanently saved in an EEPROM memory in the display and adjustment module and remain there even in case of power failure. From there, they can be written into one or more sensors or kept as backup for a possible sensor exchange.

The type and the volume of the copied data depend on the respective sensor.



Note:

Before the data are stored in the sensor, a check is carried out to determine if the data fit the sensor. If the data do not fit, a fault signal is triggered or the function is blocked. When data are being written into the sensor, the display shows which instrument type the data originate from and which TAG-no. this sensor had.

Info - Instrument name

In this menu, you read out the instrument name and the instrument serial number:

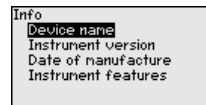
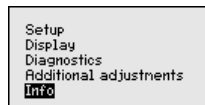

Info - Instrument version

In this menu item, the hardware and software version of the sensor is displayed.

¹⁾ The 4 ... 20 mA signal of the HART sensor is switched off. The sensor consumes a constant current of 4 mA. The measuring signal is transmitted exclusively as digital HART signal.

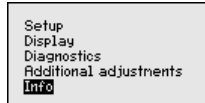

Info - Date of manufacture In this menu item, the date of factory calibration of the sensor as well as the date of the last change of sensor parameters are displayed via the display and adjustment module or via the PC.

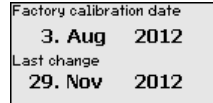
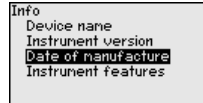
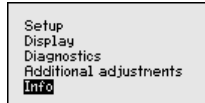

Instrument features

In this menu item, the features of the sensor such as approval, process fitting, seal, measuring range, electronics, housing and others are displayed.

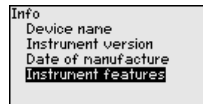
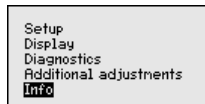

6.5 Saving the parameter adjustment data

We recommended noting the adjusted data, e.g. in this operating instructions manual, and archiving them afterwards. They are thus available for multiple use or service purposes.

If the instrument is equipped with a display and adjustment module, the data in the sensor can be saved in the display and adjustment module. The procedure is described in the operating instructions manual "*Display and adjustment module*" in the menu item "*Copy sensor data*". The data remain there permanently even if the sensor power supply fails.

The following data or settings for adjustment of the display and adjustment module are saved:

- All data of the menu "*Setup*" and "*Display*"
- In the menu "*Additional settings*" the items "*Sensor-specific units, temperature unit and linearization*"
- The values of the user programmable linearization curve

The function can also be used to transfer settings from one instrument to another instrument of the same type. If it is necessary to exchange a sensor, the display and adjustment module is inserted into the replacement instrument and the data are likewise written into the sensor via the menu item "*Copy sensor data*".

7 Setup with PACTware

7.1 Connect the PC

Via the interface adapter directly on the sensor

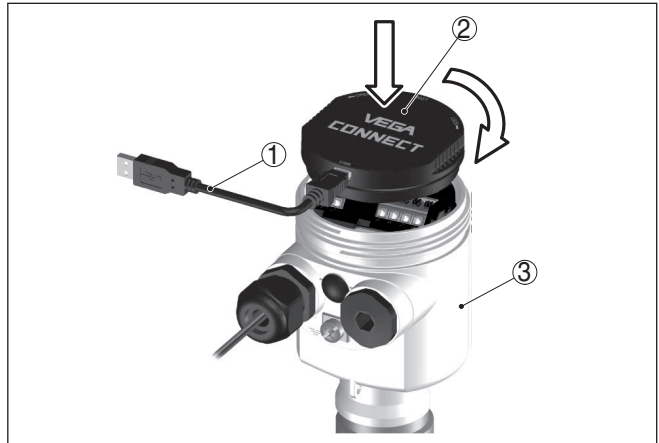

Fig. 37: Connection of the PC directly to the sensor via the interface adapter

- 1 USB cable to the PC
- 2 Interface adapter VEGACONNECT
- 3 Sensor

Via the interface adapter and HART

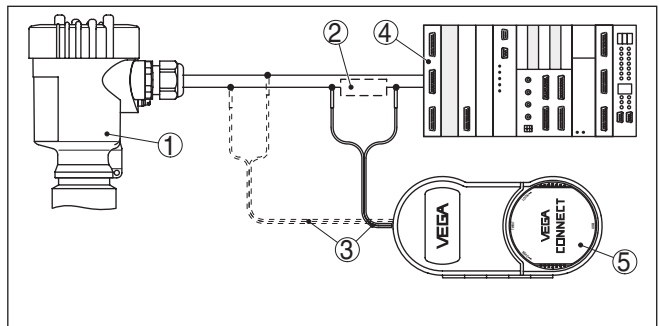

Fig. 38: Connecting the PC via HART to the signal cable

- 1 Sensor
- 2 HART resistance 250 Ω (optional depending on processing)
- 3 Connection cable with 2 mm pins and terminals
- 4 Processing system/PLC/Voltage supply
- 5 Interface adapter, for example VEGACONNECT 4



Note:

With power supply units with integrated HART resistance (internal resistance approx. 250 Ω), an additional external resistance is not necessary. This applies, e.g. to the VEGA instruments VEGATRENN 149A, VEGAMET 381, VEGAMET 391. Common Ex separators are also usually equipped with a sufficient current limitation resistance. In

such cases, the interface converter can be connected parallel to the 4 ... 20 mA cable (dashed line in the previous illustration).

7.2 Parameter adjustment

Prerequisites

For parameter adjustment of the instrument via a Windows PC, the configuration software PACTware and a suitable instrument driver (DTM) according to FDT standard are required. The latest PACTware version as well as all available DTMs are compiled in a DTM Collection. The DTMs can also be integrated into other frame applications according to FDT standard.



Note:

To ensure that all instrument functions are supported, you should always use the latest DTM Collection. Furthermore, not all described functions are included in older firmware versions. You can download the latest instrument software from our homepage. A description of the update procedure is also available in the Internet.

Further setup steps are described in the operating instructions manual "DTM Collection/PACTware" attached to each DTM Collection and which can also be downloaded from the Internet. Detailed descriptions are available in the online help of PACTware and the DTMs.

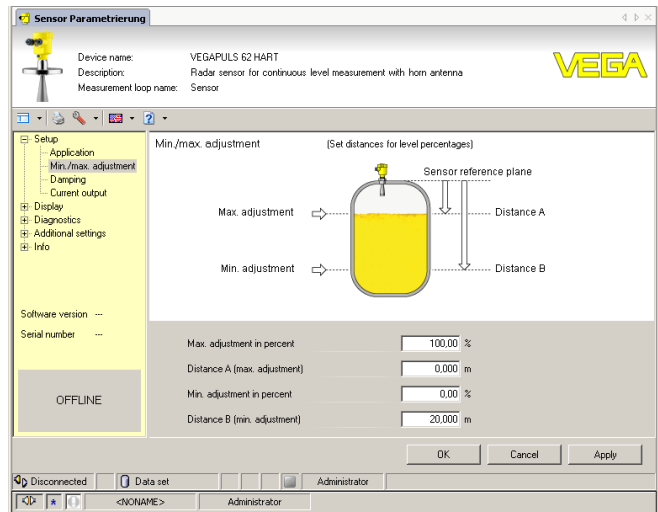

Fig. 39: Example of a DTM view

Standard/Full version

All device DTMs are available as a free-of-charge standard version and as a full version that must be purchased. In the standard version, all functions for complete setup are already included. An assistant for simple project configuration simplifies the adjustment considerably. Saving/printing the project as well as import/export functions are also part of the standard version.

In the full version there is also an extended print function for complete project documentation as well as a save function for measured value

and echo curves. In addition, there is a tank calculation program as well as a multiviewer for display and analysis of the saved measured value and echo curves.

The standard version is available as a download under www.vega.com/downloads and "Software". The full version is available on CD from the agency serving you.

7.3 Saving the parameter adjustment data

We recommend documenting or saving the parameter adjustment data via PACTware. That way the data are available for multiple use or service purposes.

8 Set up with other systems

8.1 DD adjustment programs

Device descriptions as Enhanced Device Description (EDD) are available for DD adjustment programs such as, for example, AMS™ and PDM.

The files can be downloaded at www.vega.com/downloads under "Software".

8.2 Field Communicator 375, 475

Device descriptions for the instrument are available as EDD for parameter adjustment with the Field Communicator 375 or 475.

For the integration of the EDD in the Field Communicator 375 or 475, the software "Easy Upgrade Utility" is required which is available from the manufacturer. This software is updated via the Internet and new EDDs are automatically taken over into the device catalogue of this software after they are released by the manufacturer. They can then be transferred to a Field Communicator.

9 Diagnosis, asset management and service

9.1 Maintenance

If the device is used correctly, no maintenance is required in normal operation.

9.2 Measured value and event memory

The instrument has several memories which are available for diagnosis purposes. The data remain even with voltage interruption.

Measured value memory

Up to 100,000 measured values can be stored in the sensor in a ring memory. Each entry contains date/time as well as the respective measured value. Storable values are for example:

- Distance
- Filling height
- Percentage value
- Lin. percent
- Scaled
- Current value
- Meas. reliability
- Electronics temperature

When the instrument is shipped, the measured value memory is active and stores distance, measurement certainty and electronics temperature every 3 minutes.

The requested values and recording conditions are set via a PC with PACTware/DTM or the control system with EDD. Data are thus read out and also reset.

Event memory

Up to 500 events are automatically stored with a time stamp in the sensor (non-deletable). Each entry contains date/time, event type, event description and value. Event types are for example:

- Modification of a parameter
- Switch-on and switch-off times
- Status messages (according to NE 107)
- Error messages (according to NE 107)

The data are read out via a PC with PACTware/DTM or the control system with EDD.

Echo curve memory

The echo curves are stored with date and time and the corresponding echo data. The memory is divided into two sections:

Echo curve of the setup: This is used as reference echo curve for the measurement conditions during setup. Changes in the measurement conditions during operation or buildup on the sensor can thus be recognized. The echo curve of the setup is stored via:

- PC with PACTware/DTM
- Control system with EDD
- Display and adjustment module

Further echo curves: Up to 10 echo curves can be stored in a ring buffer in this memory section. Further echo curves are stored via:

- PC with PACTware/DTM
- Control system with EDD

9.3 Asset Management function

The instrument features self-monitoring and diagnostics according to NE 107 and VDI/VDE 2650. In addition to the status messages in the following tables, detailed error messages are available under menu item "Diagnostics" via the display and adjustment module, PACTware/DTM and EDD.

Status messages

The status messages are divided into the following categories:

- Failure
- Function check
- Out of specification
- Maintenance requirement

and explained by pictographs:

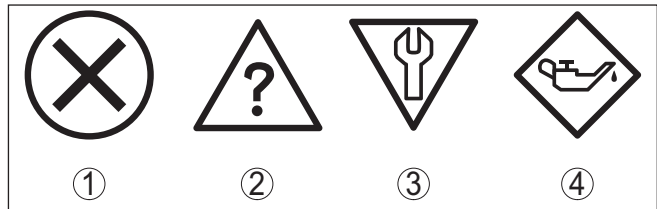

Fig. 40: Pictographs of the status messages

- 1 Failure - red
- 2 Out of specification - yellow
- 3 Function check - orange
- 4 Maintenance - blue

Failure: Due to a malfunction in the instrument, a failure message is outputted.

This status message is always active. It cannot be deactivated by the user.

Function check: The instrument is in operation, the measured value is temporarily invalid (for example during simulation).

This status message is inactive by default. It can be activated by the user via PACTware/DTM or EDD.

Out of specification: The measured value is unstable because the instrument specification is exceeded (e.g. electronics temperature).

This status message is inactive by default. It can be activated by the user via PACTware/DTM or EDD.

Maintenance: Due to external influences, the instrument function is limited. The measurement is affected, but the measured value is still valid. Plan in maintenance for the instrument because a failure is expected in the near future (e.g. due to buildup).

This status message is inactive by default. It can be activated by the user via PACTware/DTM or EDD.

Failure

The following table shows the error codes in the status message "Failure" and gives information on the reason and rectification. Keep in mind that some information is only valid with four-wire instruments.

Code Text message	Cause	Rectification	DevSpec State in CMD 48
F013 no measured value available	<ul style="list-style-type: none"> - Sensor does not detect an echo during operation - Antenna system dirty or defective 	<ul style="list-style-type: none"> - Check or correct installation and/or parameter adjustment - Clean or exchange process component or antenna 	Bit 0 of Byte 0...5
F017 Adjustment span too small	<ul style="list-style-type: none"> - Adjustment not within specification 	<ul style="list-style-type: none"> - Change adjustment according to the limit values (difference between min. and max. ≥ 10 mm) 	Bit 1 of Byte 0...5
F025 Error in the linearization table	<ul style="list-style-type: none"> - Index markers are not continuously rising, for example illogical value pairs 	<ul style="list-style-type: none"> - Check linearization table - Delete table/Create new 	Bit 2 of Byte 0...5
F036 No operable software	<ul style="list-style-type: none"> - Failed or interrupted software update 	<ul style="list-style-type: none"> - Repeat software update - Check electronics version - Exchanging the electronics - Send instrument for repair 	Bit 3 of Byte 0...5
F040 Error in the electronics	<ul style="list-style-type: none"> - Hardware defect 	<ul style="list-style-type: none"> - Exchanging the electronics - Send instrument for repair 	Bit 4 of Byte 0...5
F080 General software error	<ul style="list-style-type: none"> - General software error 	<ul style="list-style-type: none"> - Disconnect operating voltage briefly 	Bit 5 of Byte 0...5
F105 Determine measured value	<ul style="list-style-type: none"> - The instrument is still in the start phase, the measured value could not yet be determined 	<ul style="list-style-type: none"> - Wait for the end of the switch-on phase - Duration depending on the version and parameter adjustment up to approximately 3 min. 	Bit 6 of Byte 0...5

Code Text message	Cause	Rectification	DevSpec State in CMD 48
F113 Communication error	<ul style="list-style-type: none"> – EMC interference – Transmission error with the external communication with 4-wire power supply unit 	<ul style="list-style-type: none"> – Remove EMC influences – Exchange 4-wire power supply unit or electronics 	Bit 12 of Byte 0...5
F125 Impermissible electronics temperature	<ul style="list-style-type: none"> – Temperature of the electronics in the non-specified range 	<ul style="list-style-type: none"> – Check ambient temperature – Isolate electronics – Use instrument with higher temperature range 	Bit 7 of Byte 0...5
F260 Error in the calibration	<ul style="list-style-type: none"> – Error in the calibration carried out in the factory – Error in the EEPROM 	<ul style="list-style-type: none"> – Exchanging the electronics – Send instrument for repair 	Bit 8 of Byte 0...5
F261 Error in the instrument settings	<ul style="list-style-type: none"> – Error during setup – False signal suppression faulty – Error when carrying out a reset 	<ul style="list-style-type: none"> – Repeat setup – Carry out a reset 	Bit 9 of Byte 0...5
F264 Installation/Set-up error	<ul style="list-style-type: none"> – Adjustment not within the vessel height/measuring range – Max. measuring range of the instrument not sufficient 	<ul style="list-style-type: none"> – Check or correct installation and/or parameter adjustment – Use an instrument with bigger measuring range 	Bit 10 of Byte 0...5
F265 Measurement function disturbed	<ul style="list-style-type: none"> – Sensor no longer carries out a measurement – Operating voltage too low 	<ul style="list-style-type: none"> – Check operating voltage – Carry out a reset – Disconnect operating voltage briefly 	Bit 11 of Byte 0...5

Function check

The following table shows the error codes and text messages in the status message "*Function check*" and provides information on causes as well as corrective measures.

Code Text message	Cause	Rectification	DevSpec State in CMD 48
C700 Simulation active	<ul style="list-style-type: none"> – A simulation is active 	<ul style="list-style-type: none"> – Finish simulation – Wait for the automatic end after 60 mins. 	"Simulation Active" in "Standardized Status 0"

Out of specification

The following table shows the error codes and text messages in the status message "*Out of specification*" and provides information on causes as well as corrective measures.

Code Text message	Cause	Rectification	DevSpec State in CMD 48
S600 Impermissible electronics temperature	– Temperature of the electronics in the non-specified range	– Check ambient temperature – Isolate electronics – Use instrument with higher temperature range	Bit 5 of Byte 14...24
S601 Overfilling	– Danger of vessel overfilling	– Make sure that there is no further filling – Check level in the vessel	Bit 6 of Byte 14...24

Maintenance

The following table shows the error codes and text messages in the status message "Maintenance" and provides information on causes as well as corrective measures.

Code Text message	Cause	Rectification	DevSpec State in CMD 48
M500 Error with the reset delivery status	– With the reset to delivery status, the data could not be restored	– Repeat reset – Load XML file with sensor data into the sensor	Bit 0 of Byte 14...24
M501 Error in the non-active linearization table	– Hardware error EEPROM	– Exchanging the electronics – Send instrument for repair	Bit 1 of Byte 14...24
M502 Error in the diagnosis memory	– Hardware error EEPROM	– Exchanging the electronics – Send instrument for repair	Bit 2 of Byte 14...24
M503 Meas. reliability too low	– The echo/noise ratio is too small for reliable measurement	– Check installation and process conditions – Clean the antenna – Change polarisation direction – Use instrument with higher sensitivity	Bit 3 of Byte 14...24
M504 Error on an device interface	– Hardware defect	– Check connections – Exchanging the electronics – Send instrument for repair	Bit 4 of Byte 14...24
M505 No echo available	– Level echo can no longer be detected	– Clean the antenna – Use a more suitable antenna/sensor – Remove possible false echoes – Optimize sensor position and orientation	Bit 7 of Byte 14...24

9.4 Rectify faults

Reaction when malfunction occurs

The operator of the system is responsible for taking suitable measures to rectify faults.

Procedure for fault rectification

The first measures are:

- Evaluation of fault messages, for example via the display and adjustment module
- Checking the output signal
- Treatment of measurement errors

Further comprehensive diagnostics options are available with a PC with PACTware and the suitable DTM. In many cases, the reasons can be determined in this way and faults rectified.

Check the 4 ... 20 mA signal

Connect a multimeter in the suitable measuring range according to the wiring plan. The following table describes possible errors in the current signal and helps to eliminate them:

Error	Cause	Rectification
4 ... 20 mA signal not stable	- Fluctuations of the measured variable	- Set damping appropriate to the instrument via the display and adjustment module or PACTware/DTM
4 ... 20 mA signal missing	- Electrical connection faulty	- Check connection according to chapter "Connection steps" and if necessary, correct according to chapter "Wiring plan"
	- Voltage supply missing	- Check cables for breaks; repair if necessary
	- Operating voltage too low or load resistance too high	- Check, adapt if necessary
Current signal greater than 22 mA or less than 3.6 mA	- Electronics module in the sensor defective	- Exchange the instrument or send it in for repair

Treatment of measurement errors with liquids

The below tables show typical examples of application-related measurement errors with liquids. The measurement errors are differentiated according to the following:

- Constant level
- Filling
- Emptying

The images in column "Error pattern" show the real level as a broken line and the level displayed by the sensor as a continuous line.

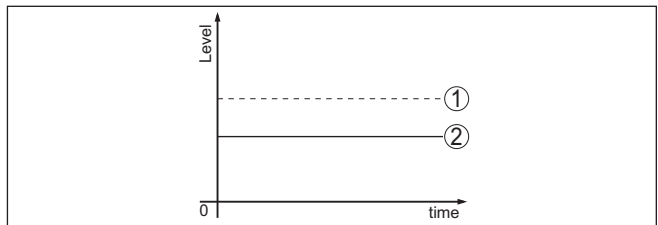

- 1 Real level
- 2 Level displayed by the sensor

Notes:

- Wherever the sensor displays a constant value, the reason could also be the fault setting of the current output to "Hold value"
- If the level indication is too low, the reason could be a line resistance that is too high

Measurement error with constant level

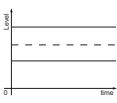
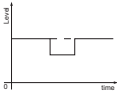
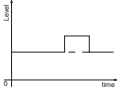
Fault description	Error pattern	Cause	Rectification
1. Measured value shows a too low or too high level		- Min./max. adjustment not correct	- Adapt min./max. adjustment
		- Incorrect linearization curve	- Adapt linearization curve
		- Installation in a bypass tube or standpipe, hence running time error (small measurement error close to 100 %/large error close to 0 %)	- Check parameter "Application" with respect to vessel form, adapt if necessary (bypass, standpipe, diameter)
2. Measured value jumps towards 0 %		- Multiple echo (vessel top, product surface) with amplitude higher than the level echo	- Check parameter "Application", especially vessel top, type of medium, dished bottom, high dielectric constant, and adapt if necessary
3. Measured value jumps towards 100 %		- Due to the process, the amplitude of the level echo sinks	- Carry out a false signal suppression
		- A false signal suppression was not carried out	
		- Amplitude or position of a false signal has changed (e.g. condensation, buildup); false signal suppression no longer matches actual conditions	- Determine the reason for the changed false signals, carry out false signal suppression, e.g. with condensation

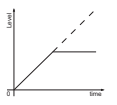
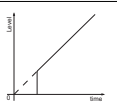

Measurement error during filling

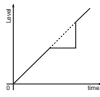
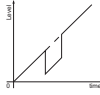
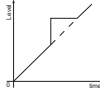
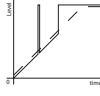
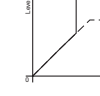
Fault description	Error pattern	Cause	Rectification
4. Measured value remains unchanged during filling		- False signals in the close range too big or level echo too small	- Eliminate false signals in the close range
		- Strong foam or spout generation	- Check measurement situation: Antenna must protrude out of the socket, installations
		- Max. adjustment not correct	- Remove contamination on the antenna
			- In case of interferences due to installations in the close range: Change polarisation direction
			- Create a new false signal suppression
			- Adapt max. adjustment
5. Measured value remains in the bottom section during filling		- Echo from the tank bottom larger than the level echo, for example, with products with $\epsilon_r < 2.5$ oil-based, solvents	- Check parameters Medium, Vessel height and Floor form, adapt if necessary

Fault description	Error pattern	Cause	Rectification
6. Measured value remains momentarily unchanged during filling and then jumps to the correct level		<ul style="list-style-type: none"> - Turbulence on the product surface, quick filling 	<ul style="list-style-type: none"> - Check parameters, change if necessary, e.g. in dosing vessel, reactor
7. Measured value jumps towards 0 % during filling		<ul style="list-style-type: none"> - Amplitude of a multiple echo (vessel top - product surface) is larger than the level echo 	<ul style="list-style-type: none"> - Check parameter "Application", especially vessel top, type of medium, dished bottom, high dielectric constant, and adapt if necessary
		<ul style="list-style-type: none"> - The level echo cannot be distinguished from the false signal at a false signal position (jumps to multiple echo) 	<ul style="list-style-type: none"> - In case of interferences due to installations in the close range: Change polarisation direction - Chose a more suitable installation position
8. Measured value jumps towards 100 % during filling		<ul style="list-style-type: none"> - Due to strong turbulence and foam generation during filling, the amplitude of the level echo sinks. Measured value jumps to the false signal 	<ul style="list-style-type: none"> - Carry out a false signal suppression
9. Measured value jumps sporadically to 100 % during filling		<ul style="list-style-type: none"> - Varying condensation or contamination on the antenna 	<ul style="list-style-type: none"> - Carry out a false signal suppression or increase false signal suppression with condensation/contamination in the close range by editing
10. Measured value jumps to $\geq 100\%$ or 0 m distance		<ul style="list-style-type: none"> - Level echo is no longer detected in the close range due to foam generation or false signals in the close range. The sensor goes into overfill protection mode. The max. level (0 m distance) as well as the status message "Overfill protection" are outputted. 	<ul style="list-style-type: none"> - Check measuring site: Antenna must protrude out of the socket - Remove contamination on the antenna - Use a sensor with a more suitable antenna

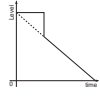
Measurement error during emptying

Fault description	Error pattern	Cause	Rectification
11. Measured value remains unchanged in the close range during emptying		<ul style="list-style-type: none"> - False signal larger than the level echo - Level echo too small 	<ul style="list-style-type: none"> - Eliminate false signal in the close range. Check: Antenna must protrude from the socket - Remove contamination on the antenna - In case of interferences due to installations in the close range: Change polarisation direction - After eliminating the false signals, the false signal suppression must be deleted. Carry out a new false signal suppression

Fault description	Error pattern	Cause	Rectification
12. Measured value jumps towards 0 % during emptying		– Echo from the tank bottom larger than the level echo, for example, with products with $\epsilon_r < 2.5$ oil-based, solvents	– Check parameters Type of medium, Vessel height and Floor form, adapt if necessary
13. Measured value jumps sporadically towards 100 % during emptying		– Varying condensation or contamination on the antenna	– Carry out false signal suppression or increase false signal suppression in the close range by editing – With bulk solids, use radar sensor with purging air connection

Reaction after fault rectification

Depending on the reason for the fault and the measures taken, the steps described in chapter "Setup" must be carried out again or must be checked for plausibility and completeness.

24 hour service hotline

Should these measures not be successful, please call in urgent cases the VEGA service hotline under the phone no. **+49 1805 858550**.

The hotline is also available outside normal working hours, seven days a week around the clock.

Since we offer this service worldwide, the support is provided in English. The service itself is free of charge, the only costs involved are the normal call charges.

9.5 Exchanging the electronics module

If the electronics module is defective, it can be replaced by the user.



In Ex applications, only instruments and electronics modules with appropriate Ex approval may be used.

If there is no electronics module available on site, the electronics module can be ordered through the agency serving you. The electronics modules are adapted to the respective sensor and differ in signal output or voltage supply.

The new electronics module must be loaded with the default settings of the sensor. These are the options:

- In the factory
- Or on site by the user

In both cases, the serial number of the sensor is needed. The serial numbers are stated on the type label of the instrument, on the inside of the housing as well as on the delivery note.

When loading on site, first of all the order data must be downloaded from the Internet (see operating instructions manual "Electronics module").



Caution:

All user-specific settings must be entered again. Hence, you have to carry out a new setup after the electronics exchange.

If you have stored the data of the parameter adjustment during the first setup of the sensor, you can transfer these to the replacement electronics module. A new setup is no more necessary.

9.6 Software update

The following components are required to update the instrument software:

- Instrument
- Voltage supply
- Interface adapter VEGACONNECT
- PC with PACTware
- Current instrument software as file

You can find the current instrument software as well as detailed information on the procedure under "www.vega.com/downloads" and "*Software*".



Caution:

Instruments with approvals can be bound to certain software versions. Therefore make sure that the approval is still effective after a software update is carried out.

You can find detailed information at www.vega.com/downloads and "*Approvals*".

9.7 How to proceed if a repair is necessary

You can find a repair form as well as detailed information on how to proceed at www.vega.com/downloads and "*Forms and certificates*".

By doing this you help us carry out the repair quickly and without having to call back for needed information.

If a repair is necessary, please proceed as follows:

- Print and fill out one form per instrument
- Clean the instrument and pack it damage-proof
- Attach the completed form and, if need be, also a safety data sheet outside on the packaging
- Please contact the agency serving you to get the address for the return shipment. You can find the agency on our home page www.vega.com.

10 Dismount

10.1 Dismounting steps

**Warning:**

Before dismantling, be aware of dangerous process conditions such as e.g. pressure in the vessel or pipeline, high temperatures, corrosive or toxic products etc.

Take note of chapters "*Mounting*" and "*Connecting to power supply*" and carry out the listed steps in reverse order.

10.2 Disposal

The instrument consists of materials which can be recycled by specialised recycling companies. We use recyclable materials and have designed the parts to be easily separable.

Correct disposal avoids negative effects on humans and the environment and ensures recycling of useful raw materials.

Materials: see chapter "*Technical data*"

If you have no way to dispose of the old instrument properly, please contact us concerning return and disposal.

WEEE directive 2002/96/EG

This instrument is not subject to the WEEE directive 2002/96/EG and the respective national laws. Pass the instrument directly on to a specialised recycling company and do not use the municipal collecting points. These may be used only for privately used products according to the WEEE directive.

11 Supplement

11.1 Technical data

General data

316L corresponds to 1.4404 or 1.4435

Materials, wetted parts with encapsulated antenna system

- Process fitting PVDF, 316L
- Process seal FKM (IDG FKM 13-75)
- Antenna PVDF

Materials, wetted parts with plastic horn antenna

- Adapter flange PP-GF30 black
- Seal, adapter flange FKM (COG VI500), EPDM (COG AP310)
- Antenna PBT-GF 30
- Focussing lense PP

Materials, non-wetted parts

- Compression flange PP-GF30 black
- Mounting strap 316L
- Fixing screws, mounting strap 316L
- Fixing screws, adapter flange 304
- Plastic housing plastic PBT (Polyester)
- Aluminium die-casting housing Aluminium die-casting AlSi10Mg, powder-coated - basis: Polyester
- Stainless steel housing 316L
- Seal between housing and housing cover NBR (stainless steel housing, precision casting), silicone (aluminium/plastic housing; stainless steel housing, electropolished)
- Inspection window in housing cover (optional) Polycarbonate
- Ground terminal 316L

Process fittings

- Pipe thread, cylindrical (ISO 228 T1) G1½
- American pipe thread, conically 1½ NPT
- Flanges DIN from DN 80, ASME from 3", JIS from DN 100 10K
- Hygienic fittings Clamp, slotted nut according to DIN 11851, Tuchenha-gen Varivent

Weight depending on process fitting and housing material 0.7 ... 3.4 kg (1.543 ... 7.496 lbs)

Max. torque, mounting screws - strap on the sensor housing 4 Nm

Max. torque flange screws

- Compression flange DN 80 5 Nm (3.689 lbf ft)
- Adapter flange DN 100 7 Nm (5.163 lbf ft)

Max. torque for NPT cable glands and Conduit tubes

- Plastic housing 10 Nm (7.376 lbf ft)
- Aluminium/Stainless steel housing 50 Nm (36.88 lbf ft)

Input variable

Measured variable The measured quantity is the distance between process fitting of the sensor and product surface. The reference plane is the seal surface on the hexagon or the lower side of the flange.

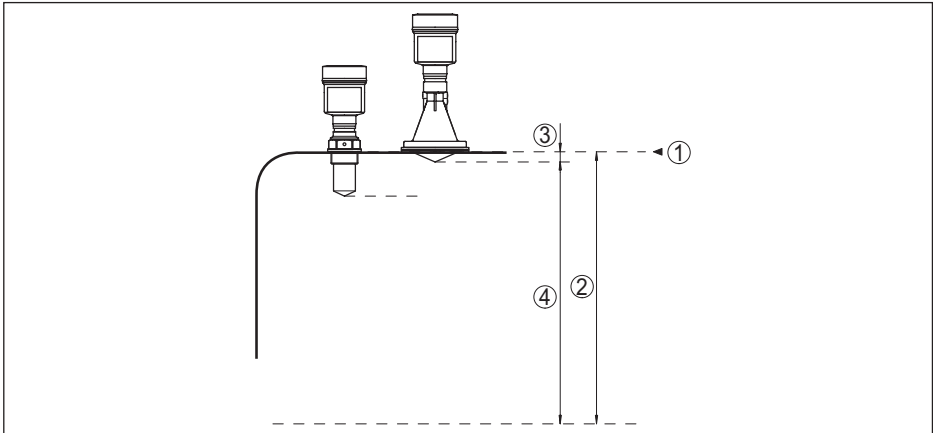

Fig. 55: Data of the input variable

- 1 Reference plane
- 2 Measured variable, max. measuring range
- 3 Antenna length
- 4 Useful measuring range

Standard electronics

- Max. measuring range 35 m (114.8 ft)
- Recommended measuring range
 - Encapsulated antenna system up to 10 m (32.81 ft)
 - Plastic horn antenna up to 20 m (65.62 ft)

Electronics with increased sensitivity

- Max. measuring range 35 m (114.8 ft)
- Recommended measuring range
 - Encapsulated antenna system up to 10 m (32.81 ft)
 - Plastic horn antenna up to 20 m (65.62 ft)

Output variable

- Output signal 4 ... 20 mA/HART
- Range of the output signal 3.8 ... 20.5 mA/HART (default setting)
- Signal resolution 0.3 μ A

Resolution, digital	< 1 mm (0.039 in)
Failure signal current output (adjustable)	mA-value unchanged 20.5 mA, 22 mA, < 3.6 mA
Max. output current	22 mA
Starting current	≤ 3.6 mA; ≤ 10 mA for 5 ms after switching on
Load	see load diagram under Power supply
Damping (63 % of the input variable), adjustable	0 ... 999 s
HART output values according to HART 7.0 ²⁾	
- PV (Primary Value)	Lin. percent
- SV (Secondary Value)	Distance
- TV (Third Value)	Meas. reliability
- QV (Fourth Value)	Electronics temperature
Fulfilled HART specification	7.0
Further information on Manufacturer ID, Device ID, Device Revision	See website of HART Communication Foundation

Accuracy (according to DIN EN 60770-1)

Process reference conditions according to DIN EN 61298-1

- Temperature +18 ... +30 °C (+64 ... +86 °F)
- Relative humidity 45 ... 75 %
- Air pressure 860 ... 1060 mbar/86 ... 106 kPa (12.5 ... 15.4 psig)

Installation reference conditions

- Min. distance to internal installations > 200 mm (7.874 in)
- Reflector Flat plate reflector
- False reflections Biggest false signal, 20 dB smaller than the useful signal

Deviation with liquids

See following diagrams

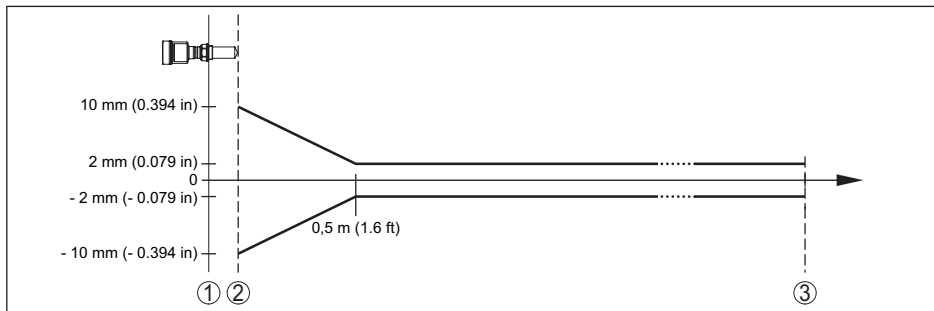

Fig. 56: Deviation under reference conditions - encapsulated antenna system

- 1 Reference plane
- 2 Antenna edge
- 3 Recommended measuring range

²⁾ Default values, can be assigned individually

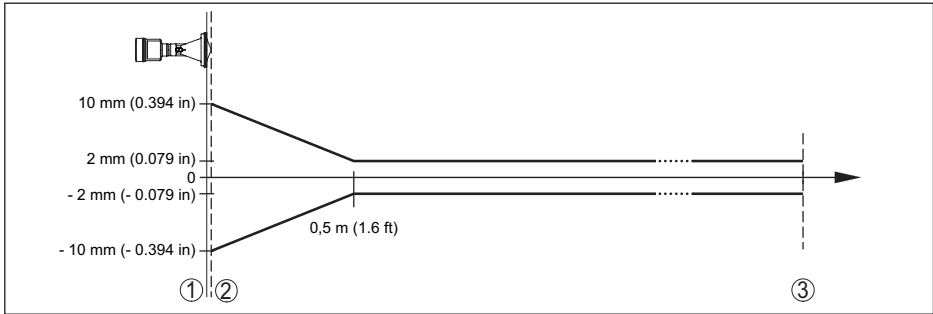

Fig. 57: Deviation under reference conditions - plastic horn antenna

- 1 Reference plane
- 2 Antenna edge
- 3 Recommended measuring range

Repeatability	≤ ±1 mm
Deviation with bulk solids	The values depend to a great extent on the application. Binding specifications are thus not possible.

Variables influencing measurement accuracy

Specifications apply to the digital measured value

Temperature drift - Digital output	±3 mm/10 K, max. 10 mm
Additional deviation through electromagnetic interference acc. to EN 61326	< ±50 mm

Specifications apply also to the current output

Temperature drift - Current output	±0.03 %/10 K relating to the 16 mA span max. ±0.3 %
Deviation on the current output through analogue/digital conversion	< ±15 µA
Deviation in the current output due to strong, high-frequency electromagnetic fields acc. to EN 61326	< ±150 µA

Characteristics and performance data

Measuring frequency	K-band (26 GHz technology)
Measuring cycle time	
– Standard electronics approx.	450 ms
– Electronics with increased sensitivity approx.	700 ms
Step response time ³⁾	≤ 3 s
Beam angle ⁴⁾	
– Encapsulated antenna system	22°
– Plastic horn antenna	10°

³⁾ Time span after a sudden measuring distance change by max. 0.5 m in liquid applications, max 2 m with bulk solids applications, until the output signal has taken for the first time 90 % of the final value (IEC 61298-2).
⁴⁾ Outside the specified beam angle, the energy of the radar signal is reduced by 50 % (-3 dB).

Emitted HF power (depending on the parameter adjustment)⁵⁾

- Average spectral transmission power density -14 dBm/MHz EIRP
- Max. spectral transmission power density +43 dBm/50 MHz EIRP
- Max. power density at a distance of 1 m < 1 $\mu\text{W}/\text{cm}^2$

Ambient conditions

Ambient, storage and transport temperature -40 ... +80 °C (-40 ... +176 °F)

Process conditions

For the process conditions, please also note the specifications on the type label. The lower value always applies.

Vessel pressure

- Encapsulated antenna system -1 ... 3 bar (-100 ... 300 kPa/-14.5 ... 43.5 psi)
- Plastic horn antenna -1 ... 2 bar (-100 ... 200 kPa/-14.5 ... 29.0 psig)
- Version with adapter flange from DN100 PP or PP-GF 30 -1 ... 1 bar (-100 ... 100 kPa/-14.5 ... 14.5 psig)

Process temperature (measured on the process fitting) -40 ... +80 °C (-40 ... +176 °F)

Vibration resistance

- With adapter flange 2 g at 5 ... 200 Hz according to EN 60068-2-6 (vibration with resonance)
- with mounting strap 1 g at 5 ... 200 Hz according to EN 60068-2-6 (vibration with resonance)

Shock resistance

100 g, 6 ms according to EN 60068-2-27 (mechanical shock)

Electromechanical data - version IP 66/IP 67 and IP 66/IP 68; 0.2 bar

Cable gland M20 x 1.5 or ½ NPT

Wire cross-section (spring-loaded terminals)

- Massive wire, stranded wire 0.2 ... 2.5 mm² (AWG 24 ... 14)
- Stranded wire with end sleeve 0.2 ... 1.5 mm² (AWG 24 ... 16)

Electromechanical data - version IP 66/IP 68 (1 bar)

Options of the cable entry

- Cable gland with integrated connection cable M20 x 1.5 (cable: \varnothing 5 ... 9 mm)
- Cable entry ½ NPT
- Blind plug M20 x 1.5; ½ NPT

Connection cable

- Wire cross-section 0.5 mm² (AWG 20)

⁵⁾ EIRP: Equivalent Isotropic Radiated Power.

- Wire resistance	< 0.036 Ω/m
- Tensile strength	< 1200 N (270 lbf)
- Standard length	5 m (16.4 ft)
- Max. length	180 m (590.6 ft)
- Min. bending radius	25 mm (0.984 in) with 25 °C (77 °F)
- Diameter approx.	8 mm (0.315 in)
- Colour - Non-Ex version	Black
- Colour - Ex-version	Blue

Display and adjustment module

Display element	Display with backlight
Measured value indication	
- Number of digits	5
- Size of digits	W x H = 7 x 13 mm
Adjustment elements	4 keys
Protection rating	
- unassembled	IP 20
- mounted in the housing without lid	IP 40
Materials	
- Housing	ABS
- Inspection window	Polyester foil

Interface to the external display and adjustment unit

Data transmission	Digital (I ² C-Bus)
Connection cable	Four-wire

Sensor version	Configuration, connection cable			
	Cable length	Standard cable	Special cable	Screened
4 ... 20 mA, 4 ... 20 mA/HART	50 m	●	-	-
Profibus PA, Foundation Fieldbus	25 m	-	●	●

Integrated clock

Date format	Day.Month.Year
Time format	12 h/24 h
Time zone Ex factory	CET
Rate deviation max.	10.5 min/year

Measurement electronics temperature

Resolution	0.1 °C (1.8 °F)
Accuracy	±1 °C (1.8 °F)
Permissible temperature range	-40 ... +85 °C (-40 ... +185 °F)

Voltage supply

Operating voltage U_B

- Non-Ex instrument 9.6 ... 35 V DC
- Ex ia instrument 9.6 ... 30 V DC
- Ex-d-ia instrument 14 ... 35 V DC
- Ex-d-ia instrument with ship approval 15 ... 35 V DC

Operating voltage U_B - illuminated display and adjustment module

- Non-Ex instrument 16 ... 35 V DC
- Ex ia instrument 16 ... 30 V DC
- Ex-d-ia instrument No lighting (integrated ia barrier)

Reverse voltage protection Integrated

Permissible residual ripple - Non-Ex, Ex-ia instrument

- for $9.6 \text{ V} < U_B < 14 \text{ V}$ $\leq 0.7 V_{\text{eff}}$ (16 ... 400 Hz)
- for $18 \text{ V} < U_B < 36 \text{ V}$ $\leq 1.0 V_{\text{eff}}$ (16 ... 400 Hz)

Permissible residual ripple - Ex-d-ia instrument

- for $18 \text{ V} < U_B < 36 \text{ V}$ $\leq 1 V_{\text{eff}}$ (16 ... 400 Hz)

Load resistor

- Calculation $(U_B - U_{\text{min}})/0.022 \text{ A}$
- Example - Non-Ex instrument with $U_B = 24 \text{ V DC}$ $(24 \text{ V} - 9.6 \text{ V})/0.022 \text{ A} = 655 \Omega$

Electrical protective measures

Protection rating

Housing material	Version	IP-protection class	NEMA protection
Plastic	Single chamber	IP 66/IP 67	NEMA 4X
	Double chamber	IP 66/IP 67	NEMA 4X
Aluminium	Single chamber	IP 66/IP 68 (0.2 bar)	NEMA 6P
		IP 68 (1 bar)	NEMA 6P
	Double chamber	IP 66/IP 67	NEMA 4X
		IP 66/IP 68 (0.2 bar)	NEMA 6P
		IP 68 (1 bar)	NEMA 6P
Stainless steel, electro-polished	Single chamber	IP 66/IP 68 (0.2 bar)	NEMA 6P
Stainless steel, precision casting	Single chamber	IP 66/IP 68 (0.2 bar)	NEMA 6P
		IP 68 (1 bar)	NEMA 6P
	Double chamber	IP 66/IP 67	NEMA 4X
		IP 66/IP 68 (0.2 bar)	NEMA 6P
		IP 68 (1 bar)	NEMA 6P

Protection rating (IEC 61010-1)

III

Approvals

Instruments with approvals can have different technical specifications depending on the version.

For that reason the associated approval documents of these instruments have to be carefully noted. They come with the delivery or can be downloaded under www.vega.com, "VEGA Tools" and "Instrument search" as well as under www.vega.com/downloads and "Approvals".

Interface to the external display and adjustment unit

Data transmission Digital (I²C-Bus)
 Connection cable Four-wire

Sensor version	Configuration, connection cable			
	Cable length	Standard cable	Special cable	Screened
4 ... 20 mA, 4 ... 20 mA/HART	50 m	●	–	–
Profibus PA, Founda- tion Fieldbus	25 m	–	●	●

11.2 Dimensions

The following dimensional drawings represent only an extract of all possible versions. Detailed dimensional drawings can be downloaded at www.vega.com/downloads under "Drawings".

Plastic housing

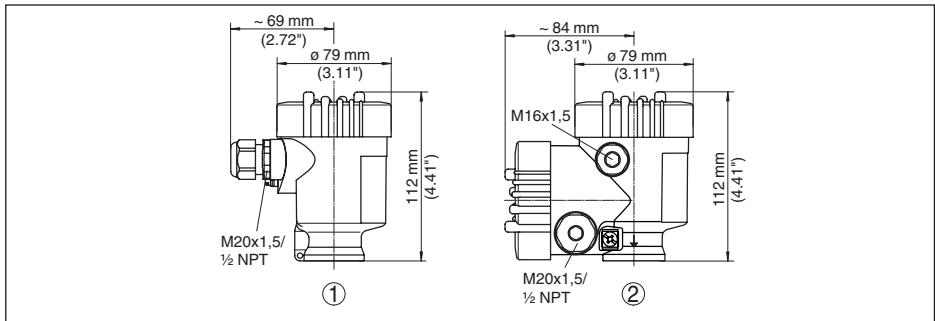

Fig. 58: Housing versions with protection rating IP 66/IP 67 - with integrated display and adjustment module the housing is 9 mm/0.35 in higher

- 1 Single chamber version
- 2 Double chamber version

Aluminium housing

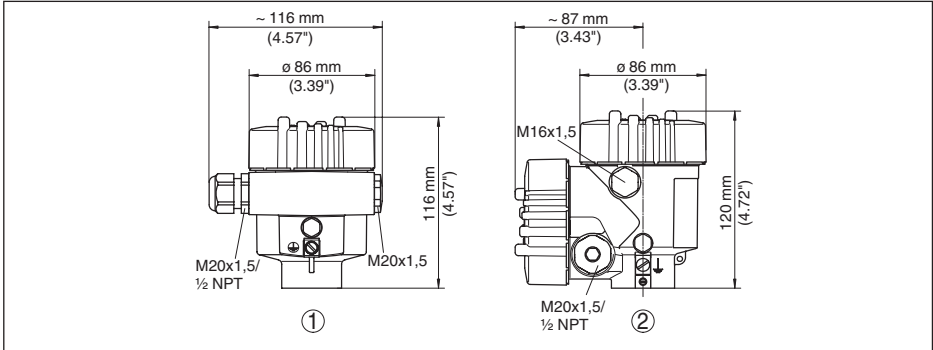

Fig. 59: Housing versions with protection rating IP 66/IP 68 (0.2 bar) - with integrated display and adjustment module the housing is 9 mm/0.35 in higher

- 1 Single chamber version
- 2 Double chamber version

Aluminium housing in protection rating IP 66/IP 68, 1 bar

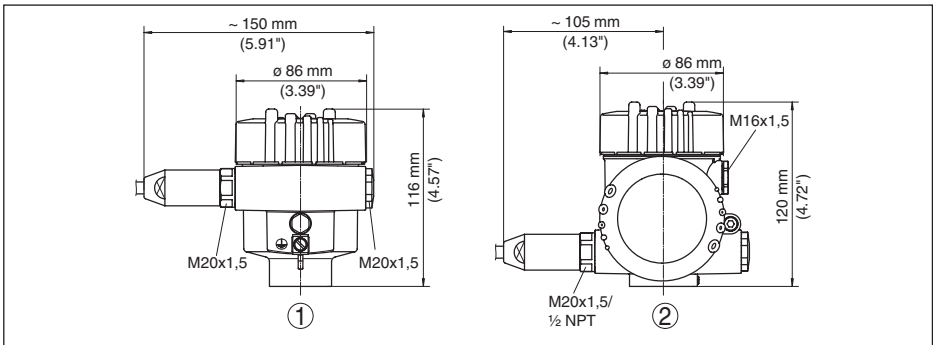

Fig. 60: Housing version with protection rating IP 66/IP 68 (1 bar) - with integrated display and adjustment module the housing is 9 mm/0.35 in higher

- 1 Single chamber version
- 2 Double chamber version

Stainless steel housing

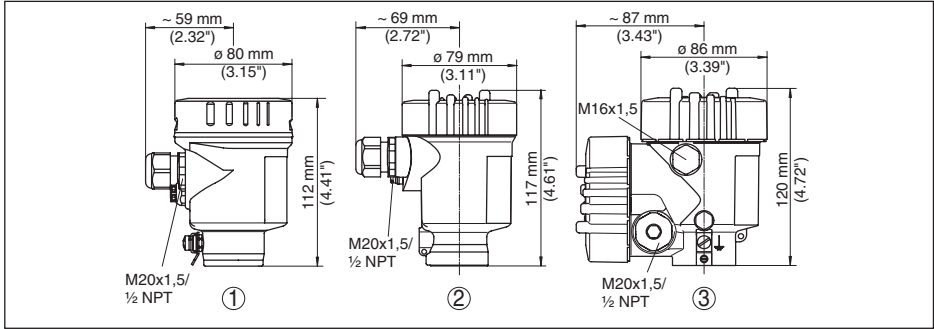

Fig. 61: Housing versions with protection rating IP 66/IP 68 (0.2 bar) - with integrated display and adjustment module the housing is 9 mm/0.35 in higher

- 1 Single chamber version, electropolished
- 2 Single chamber version, precision casting
- 3 Double chamber version, precision casting

Stainless steel housing with protection rating IP 66/IP 68, 1 bar

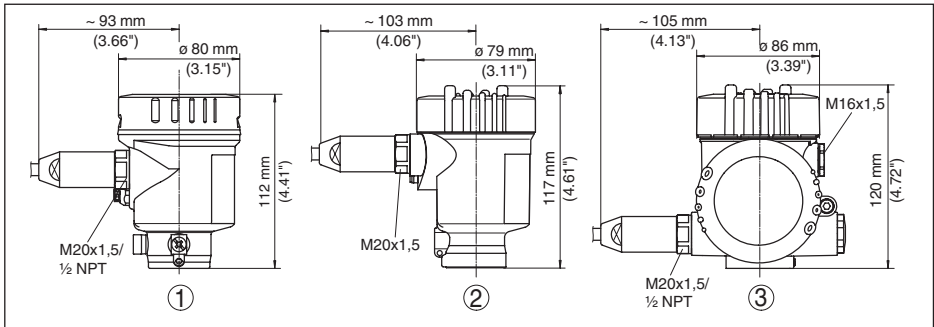

Fig. 62: Housing version with protection rating IP 66/IP 68 (1 bar) - with integrated display and adjustment module the housing is 9 mm/0.35 in higher

- 1 Single chamber version, electropolished
- 2 Single chamber version, precision casting
- 3 Double chamber version, precision casting

VEGAPULS 61, threaded version

Fig. 63: VEGAPULS 61, threaded version G1½ and 1½ NPT

VEGAPULS 61, hygienic fitting

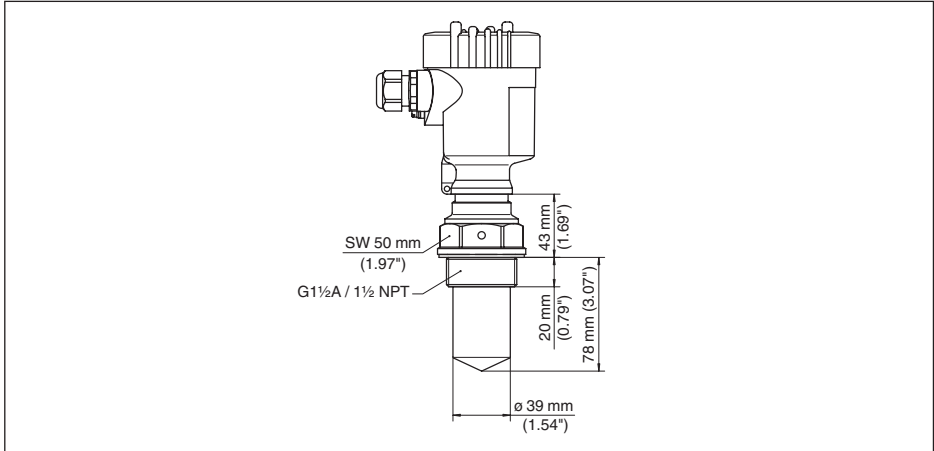
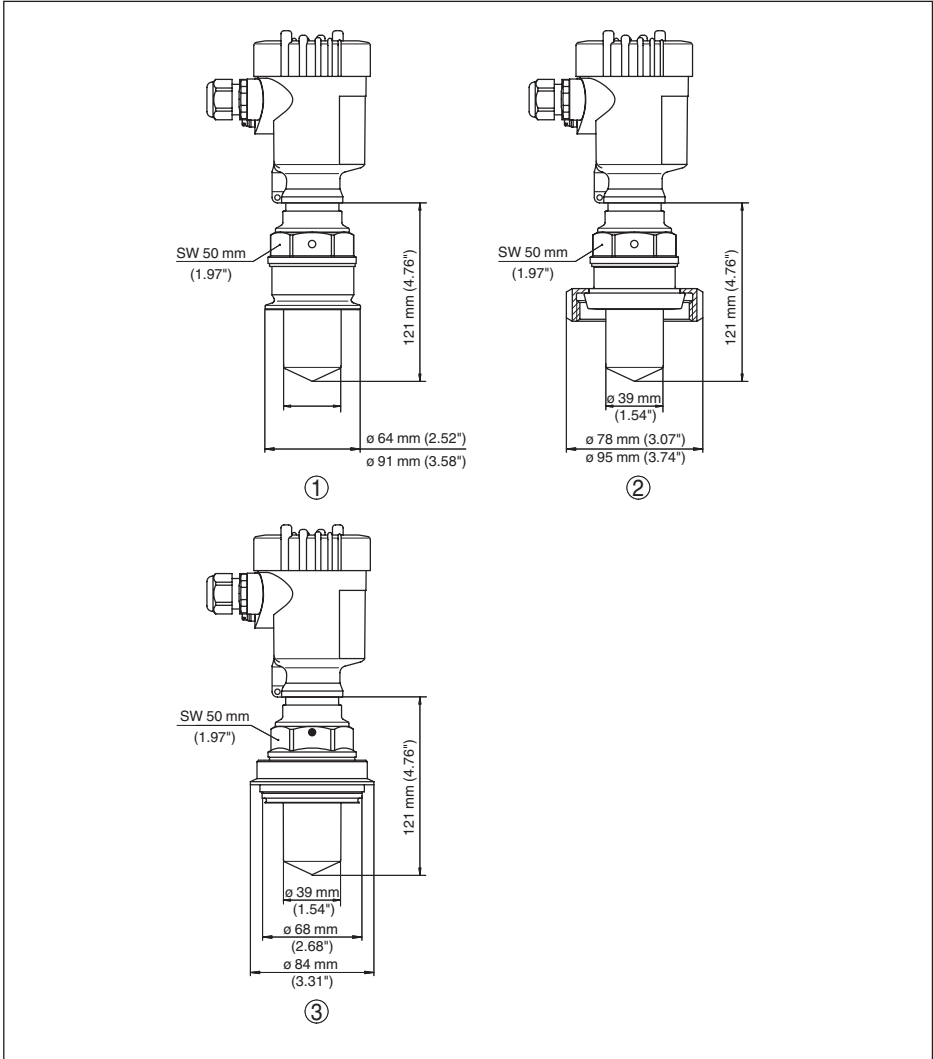

Fig. 64: VEGAPULS 61, hygienic fitting

- 1 Clamp 2" ($\phi 64$ mm) and 3" ($\phi 91$ mm) PN 16 DIN 32676, ISO 2852/316L
- 2 Slotted nut according to DIN 11851 DN 50 and DN 80
- 3 Tuchenhagen Varivent DN 32

VEGAPULS 61, version with mounting strap

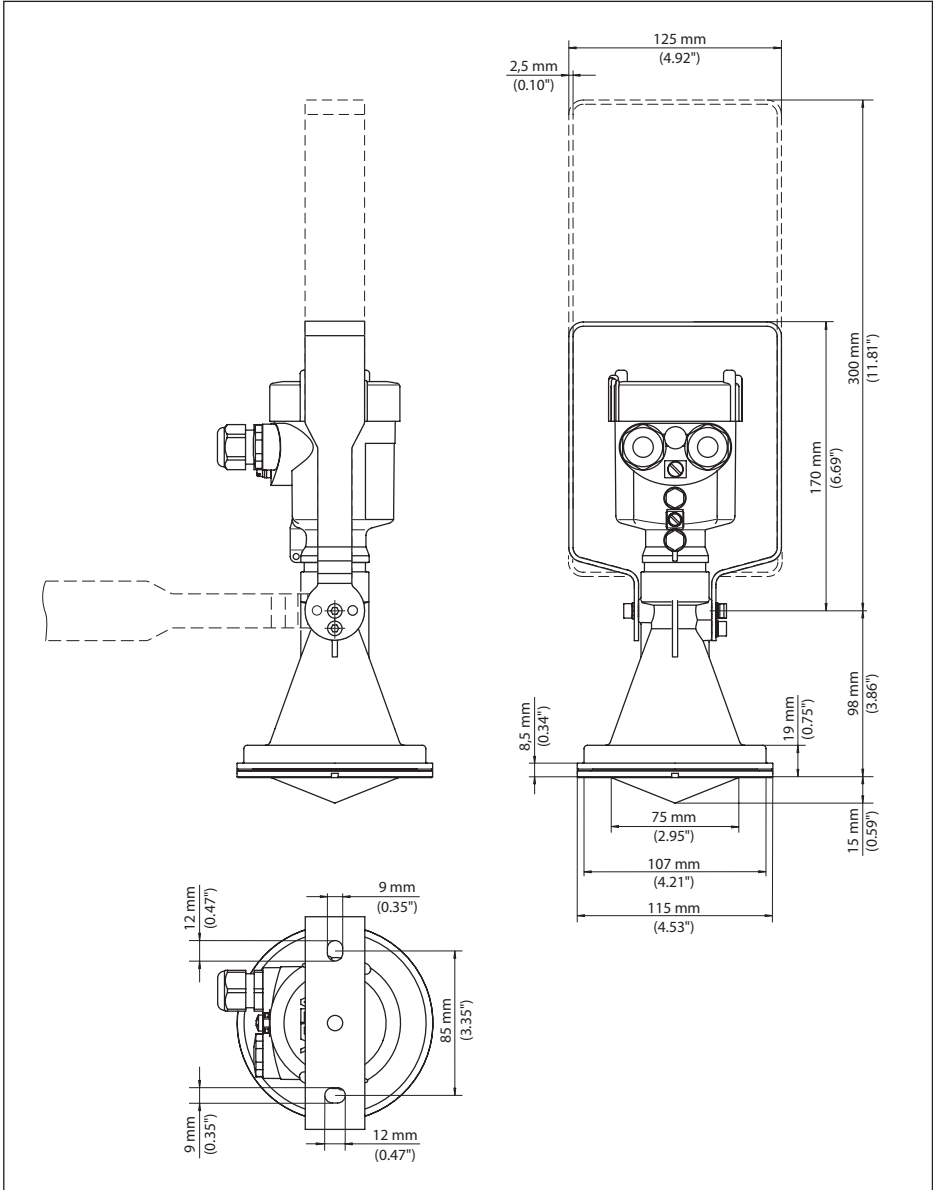

Fig. 65: VEGAPULS 61, mounting strap in 170 or 300 mm length

VEGAPULS 61, version with mounting strap and clamps

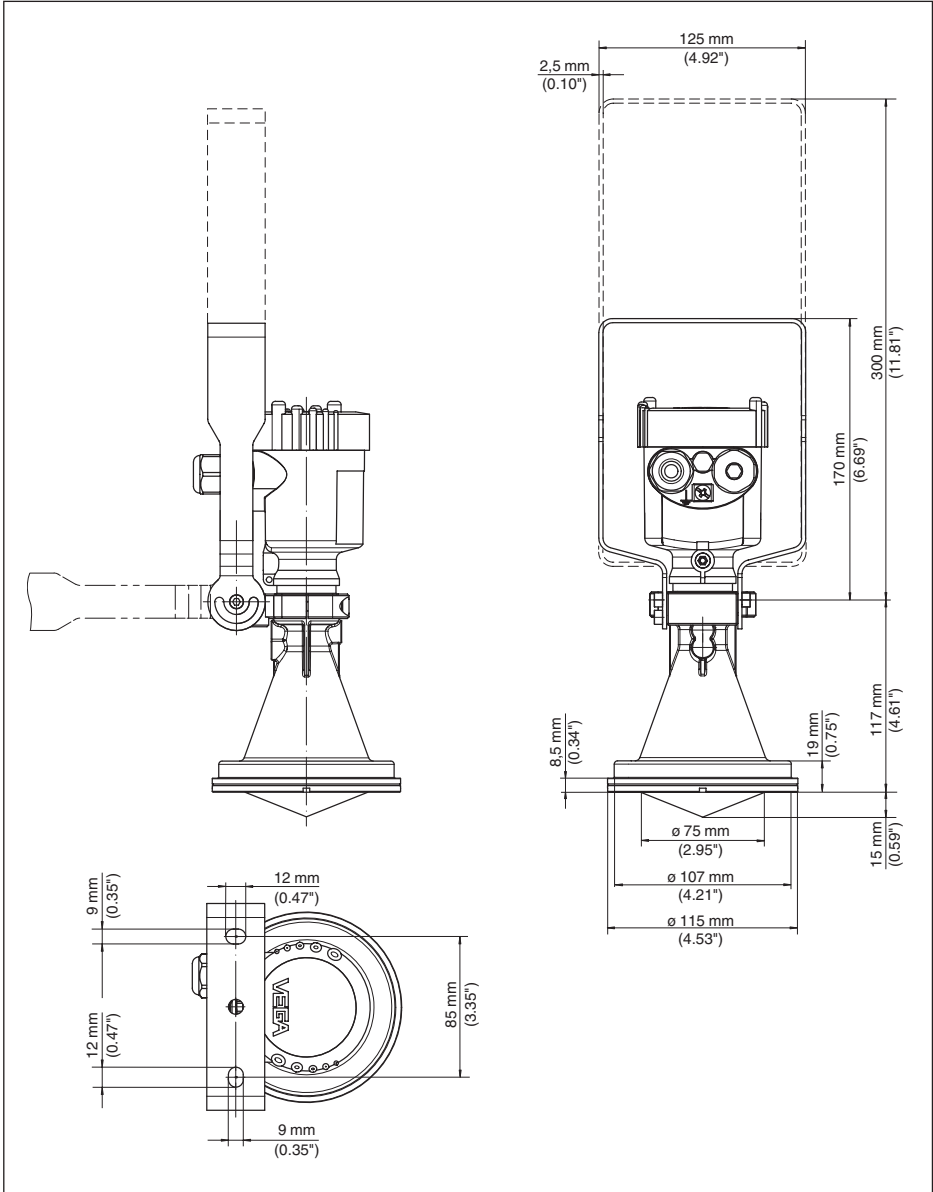
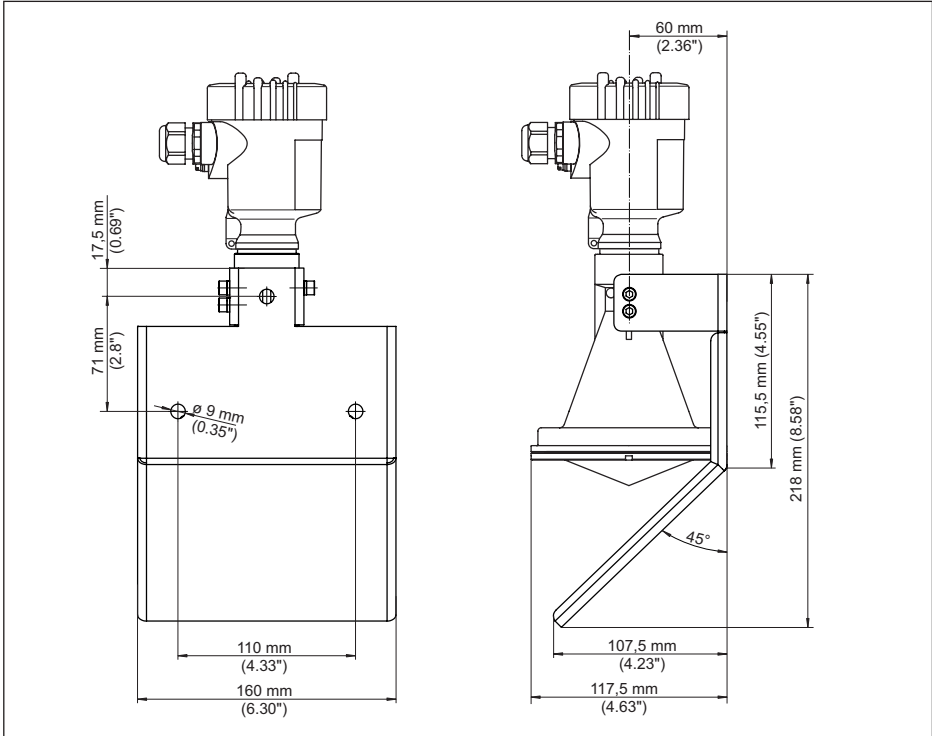

Fig. 66: VEGAPULS 61, mounting strap in 170 or 300 mm length

VEGAPULS 61, version with mounting strap and reflector*Fig. 67: VEGAPULS 61, mounting strap and reflector*

VEGAPULS 61, version with compression flange

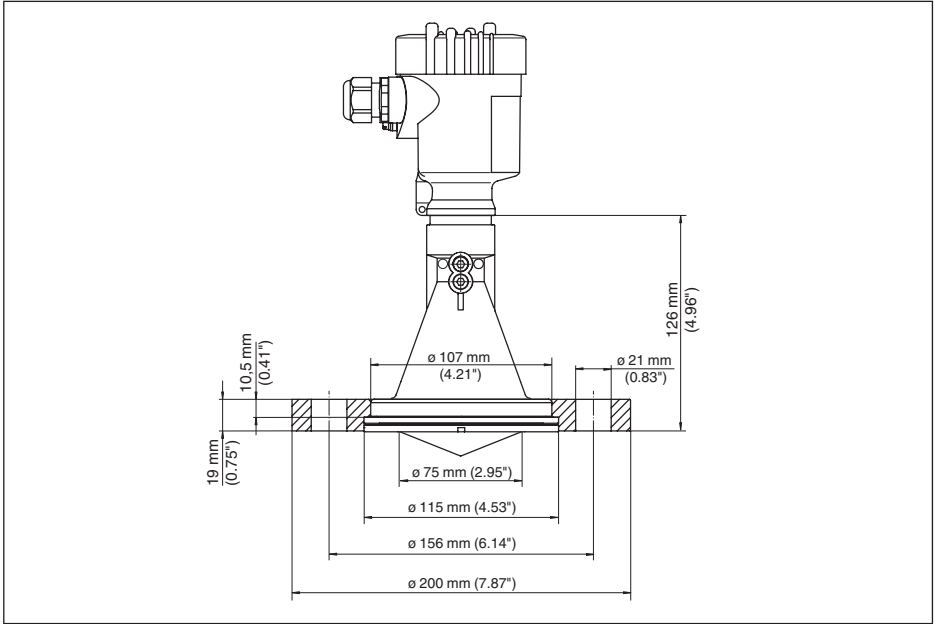

Fig. 68: VEGAPULS 61, compression flange suitable for DN 80 PN 16/ASME 3" 150lbs/JIS80 10K

VEGAPULS 61, version with compression flange and rinsing connection

Fig. 69: VEGAPULS 61, compression flange with rinsing connection suitable for DN 80 PN 16/ASME 3" 150lbs/JIS80 10K

VEGAPULS 61, version with adapter flange

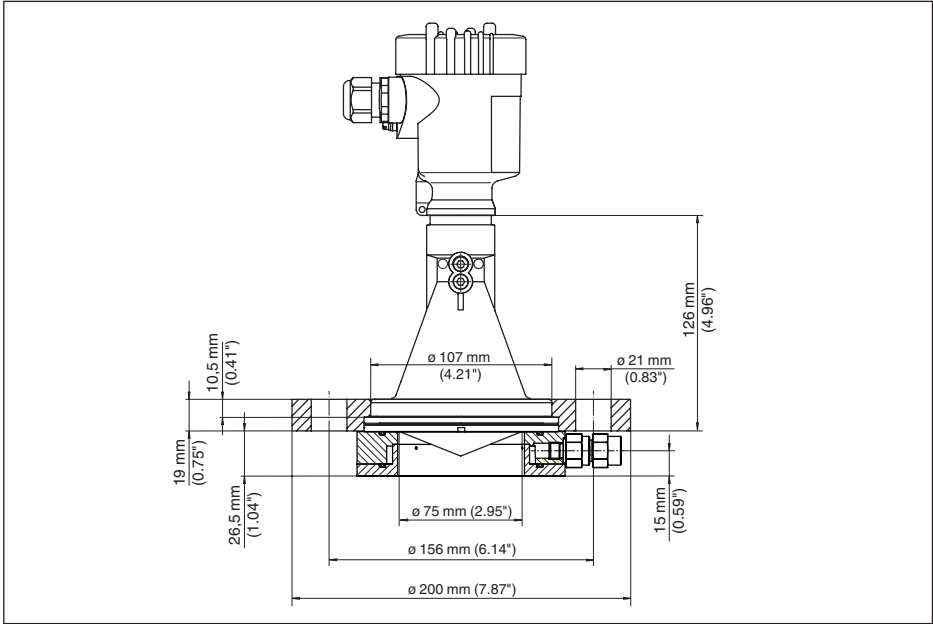
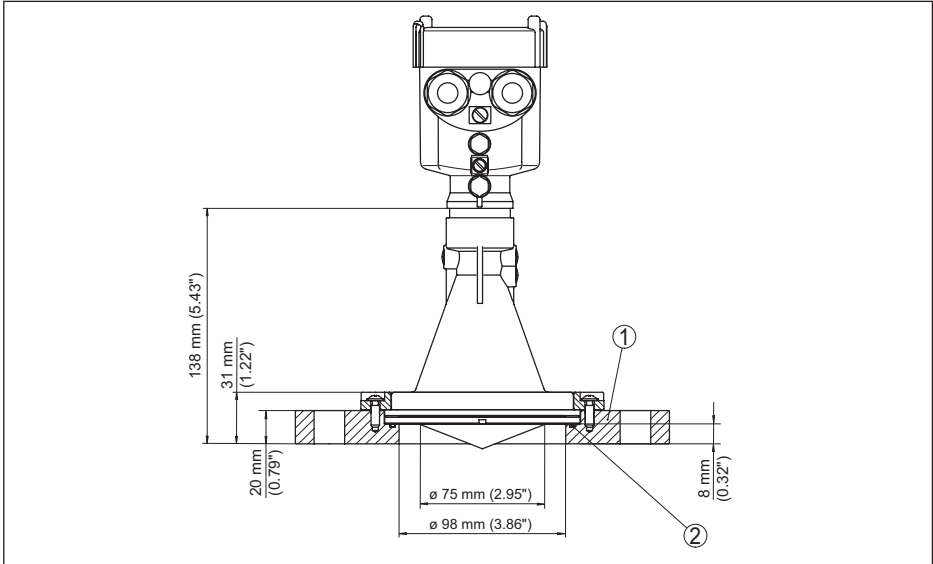

Fig. 70: VEGAPULS 61, adapter flange

- 1 Adapter flange
- 2 Seal

VEGAPULS 61, version with adapter flange and rinsing connection

Fig. 71: VEGAPULS 61, adapter flange and air rinsing

- 1 Rinsing connection
- 2 Reflux valve
- 3 Adapter flange

11.3 Industrial property rights

VEGA product lines are global protected by industrial property rights. Further information see www.vega.com.

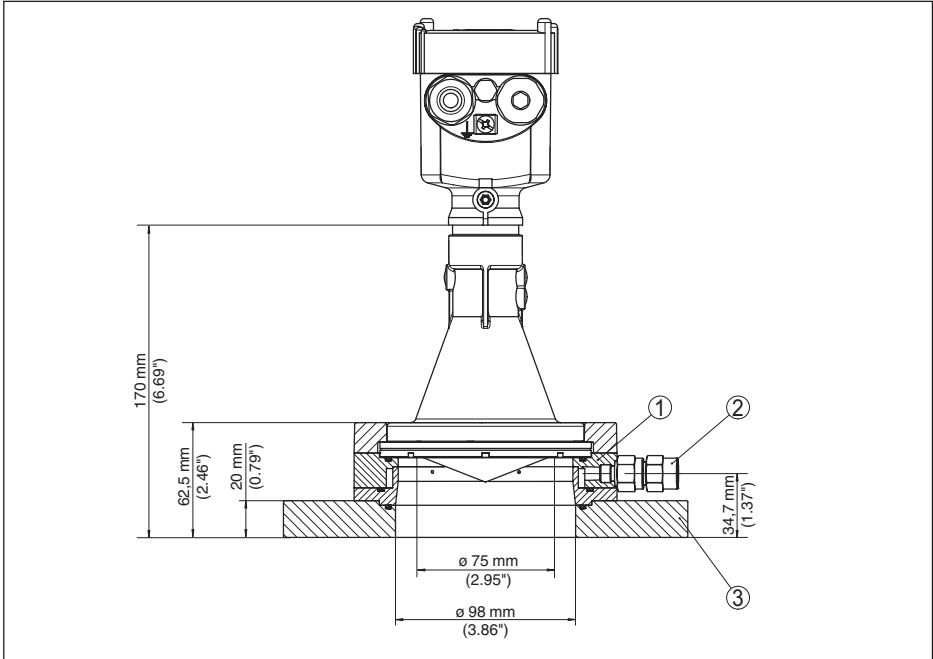
Only in U.S.A.: Further information see patent label at the sensor housing.

VEGA Produktfamilien sind weltweit geschützt durch gewerbliche Schutzrechte.

Nähere Informationen unter www.vega.com.

Les lignes de produits VEGA sont globalement protégées par des droits de propriété intellectuelle. Pour plus d'informations, on pourra se référer au site www.vega.com.

VEGA líneas de productos están protegidas por los derechos en el campo de la propiedad industrial. Para mayor información revise la pagina web www.vega.com.

Линии продукции фирмы ВЕГА защищаются по всему миру правами на интеллектуальную собственность. Дальнейшую информацию смотрите на сайте www.vega.com.

VEGA系列产品在全球享有知识产权保护。

进一步信息请参见网站www.vega.com。

11.4 Trademark

All the brands as well as trade and company names used are property of their lawful proprietor/originator.

INDEX

A

- Adjustment 47, 48
- Agitators 20
- Application
 - Bulk solid 44
 - Liquid 40
 - Standpipe 41

B

- Backlight 50

C

- Cable entry 13
- Check output signal 68
- Connecting
 - Electrically 29
 - To the PC 59
- Connection
 - Cable 28
 - Steps 29
 - Technology 29
- Copy sensor settings 57
- Current output Min./Max. 49
- Current output mode 49
- Curve indication
 - Echo curve 52
 - False signal suppression 52

D

- Damping 48
- Date/Time 55
- Default values 55
- Deviation 68
- Device units 52

E

- Echo curve memory 63
- Echo curve of the setup 52
- EDD (Enhanced Device Description) 62
- Electronics and terminal compartment, single chamber housing 31
- Electronics temperature 51
- Error codes 66
- Event memory 63

F

- False signal suppression 53
- Fault rectification 67
- Flow measurement 26, 27
- Foam generation 21

- Functional principle 10

G

- Grounding 28

H

- HART
 - Resistor 59
- HART mode 56

I

- Indication of the measured value 50
- Inflowing medium 17
- Installation position 16
- Instrument version 57

L

- Language 49
- Linearisation curve 54
- Lock adjustment 49

M

- Main menu 39
- Meas. reliability 51
- Measured value memory 63
- Measurement in a surge pipe 21
- Measurement in the bypass tube 24
- Measurement loop name 39

N

- NAMUR NE 107 65, 67

O

- Operation
 - System 38
- Overfill protection according to WHG 54

P

- Peak value indicator 50
- PIN 49, 54
- Polarisation 15

R

- Read out info 57
- Reflection properties 40
- Repair 72
- Reset 55

S

- Sensor orientation 20
- Sensor status 50

Service hotline 71
Shielding 28
Simulation 51
Socket 17, 19
Status messages - NAMUR NE 107 64

T

Type label 8

V

Vessel form 46
Vessel height 46
Vessel installations 20

Printing date:

VEGA

All statements concerning scope of delivery, application, practical use and operating conditions of the sensors and processing systems correspond to the information available at the time of printing.

Subject to change without prior notice

© VEGA Grieshaber KG, Schiltach/Germany 2015



36499-EN-150625

VEGA Grieshaber KG
Am Hohenstein 113
77761 Schiltach
Germany

Phone +49 7836 50-0
Fax +49 7836 50-201
E-mail: info.de@vega.com
www.vega.com